

ISTEQ

OPTOPRIM



ISTEQ Broadband plasma light sources

- XWS-65: Basic configuration
- XWS-Dual port: Two light outputs
- XWS-R: High power light source
- XWS-X: Ultra high brightness
- XWS-30: Compact light source
- Hyperchromator: Tunable light source

XWS-65 broadband plasma light source

XWS-65 laser pumped plasma ultrabright broadband light source

ISTEQ's XWS-65 light source product has been specially developed to be used for a variety of applications, including spectroscopy, high resolution microscopy, thin - film measurement, surface metrology and others. This source is based on cutting edge technology, covered by EU and US patents.



Application fields:

- Absorption and fluorescence spectroscopy
- Diagnostics systems in microelectronics - contamination and defect control
- Surface metrology, ellipsometry and scatterometry
- Microscopy, including confocal and fluorescence
- Optical component testing
- Detectors in chromatography, microfluidics, lab-on-a-chip, droplet spectrometers, cytofluorimeters, etc

Main advantages:

- CW laser plasma discharge
- Broad spectral range: 190 – 2500 nm
- High spectral brightness: up to 50 mW/(mm²·sr·nm)
- High temporal and spatial stability: STD < 0.15%
- Long life time due to electrodeless operation: 10,000 hours
- The small dimensions of the emitting volume considerably expand the range of XWS applications
- External source control and parameters monitoring via Software, Windows GUI

Spectral brightness of XWS-65 light source in UV and VIS spectral region

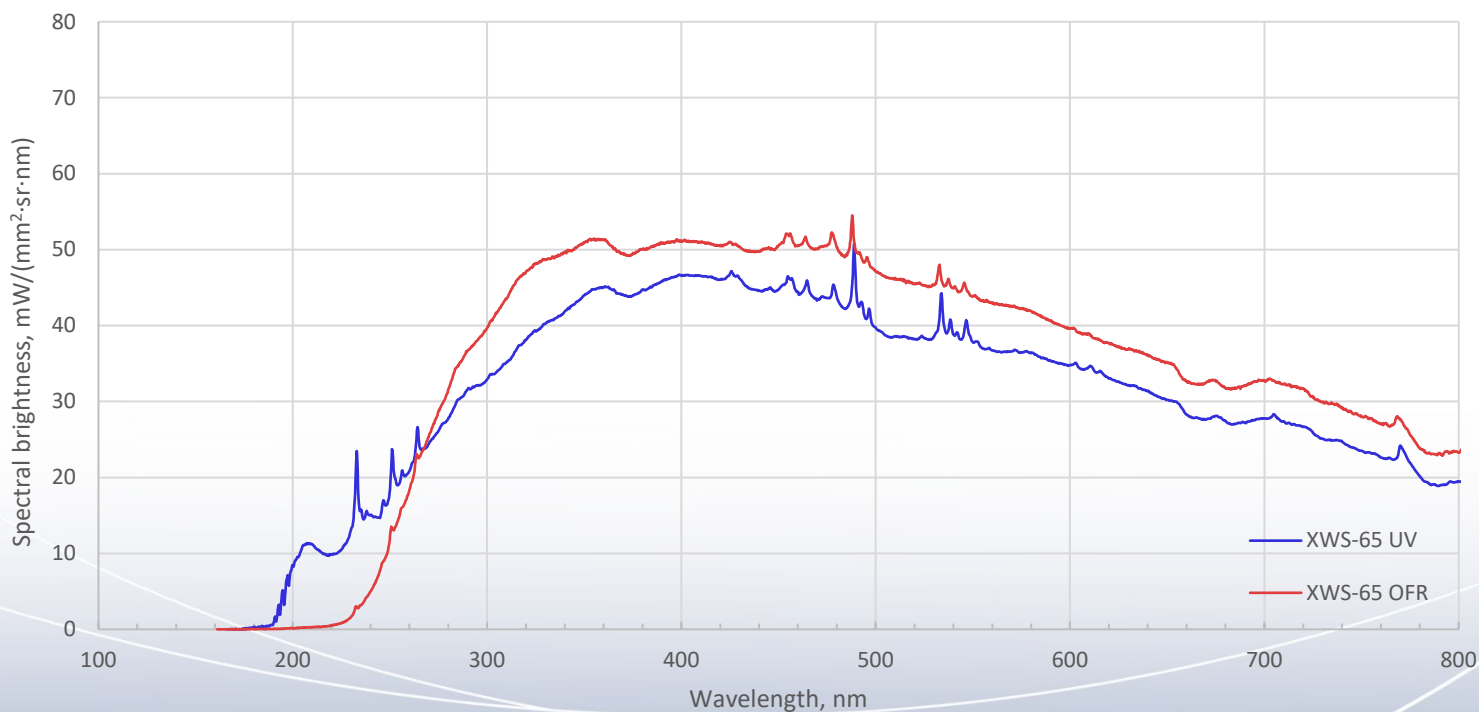

XWS-65 broadband plasma light source

XWS-65 performance

Spectral range	190 - 2500nm for UV configuration, 250 - 2500nm for OFR configuration
Spectral brightness	Up to 50mW/(mm ² ·sr·nm)
Output power	Up to 3 W free space Up to 0.5 W via fiber
Lamp medium	Xenon
Emitting body size	250×500um
Lifetime	10,000 hours
Temporal and spatial stability	STD < 0.15%

Optical design

Output NA by default	0.4, up to 0.55 upon request
External optic interface by default	C-mount
Optional output interface	Thorlabs SM1, 30mm cage and more
Fiber interface (only for FCU version)	SMA or FC

Optional configurations

Source spectrum	UV or Ozone free
Light output	Free space or fiber coupled
Optical head cooling unit	Air or water cooling
Power Supply Unit (PSU) cooling system	Air or water cooling

Additional

Connection to PC/Laptop	Ethernet (Web interface), COM-port (RS232)
Interlock	Db-15 connector
Remote plasma control	Db-15 connector

System dimensions and weight

Optical head Free Space	130 × 110 × 74mm, 1.3kg
Power supply unit	351 × 172 × 232mm, 8kg

Facility requirements

Electrical	100-240V, 50/60Hz
Gas purging (only for UV configuration)	Nitrogen or Argon purging, 1l/min

XWS-65 broadband plasma light source

Optical head (Free Space) dimensions:

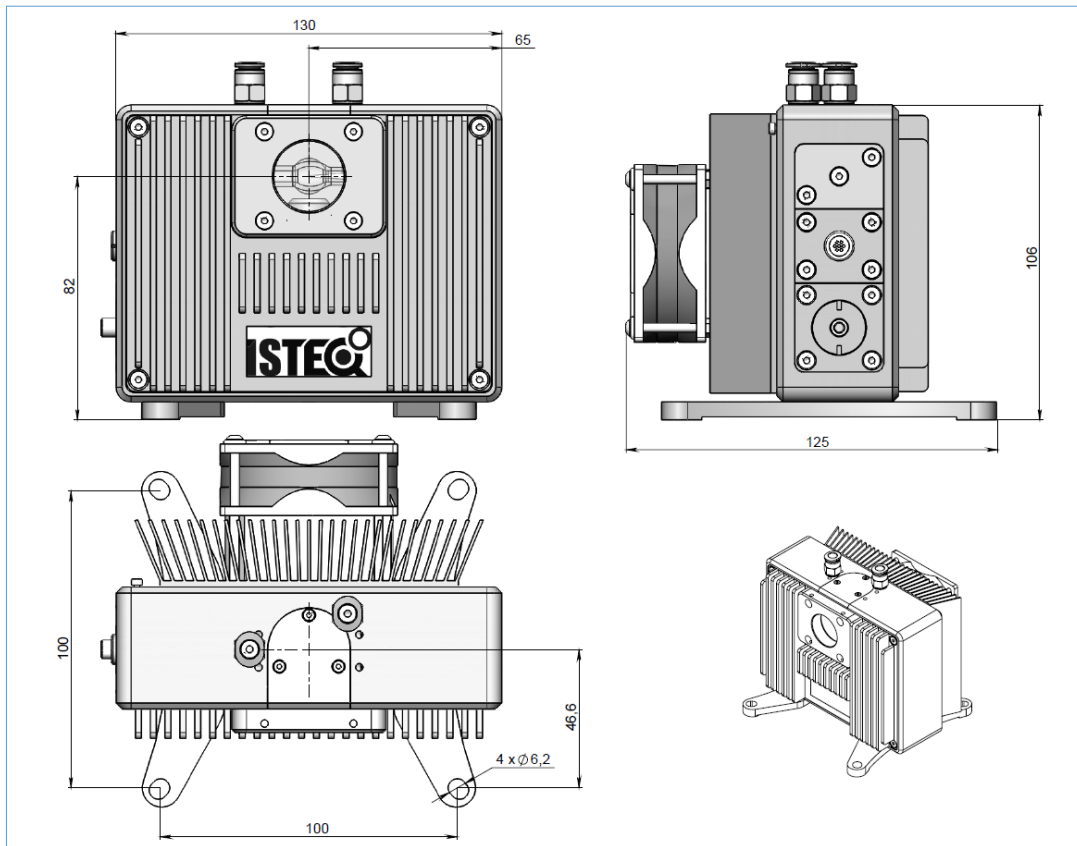

Power Supply Unit (PSU) dimensions:

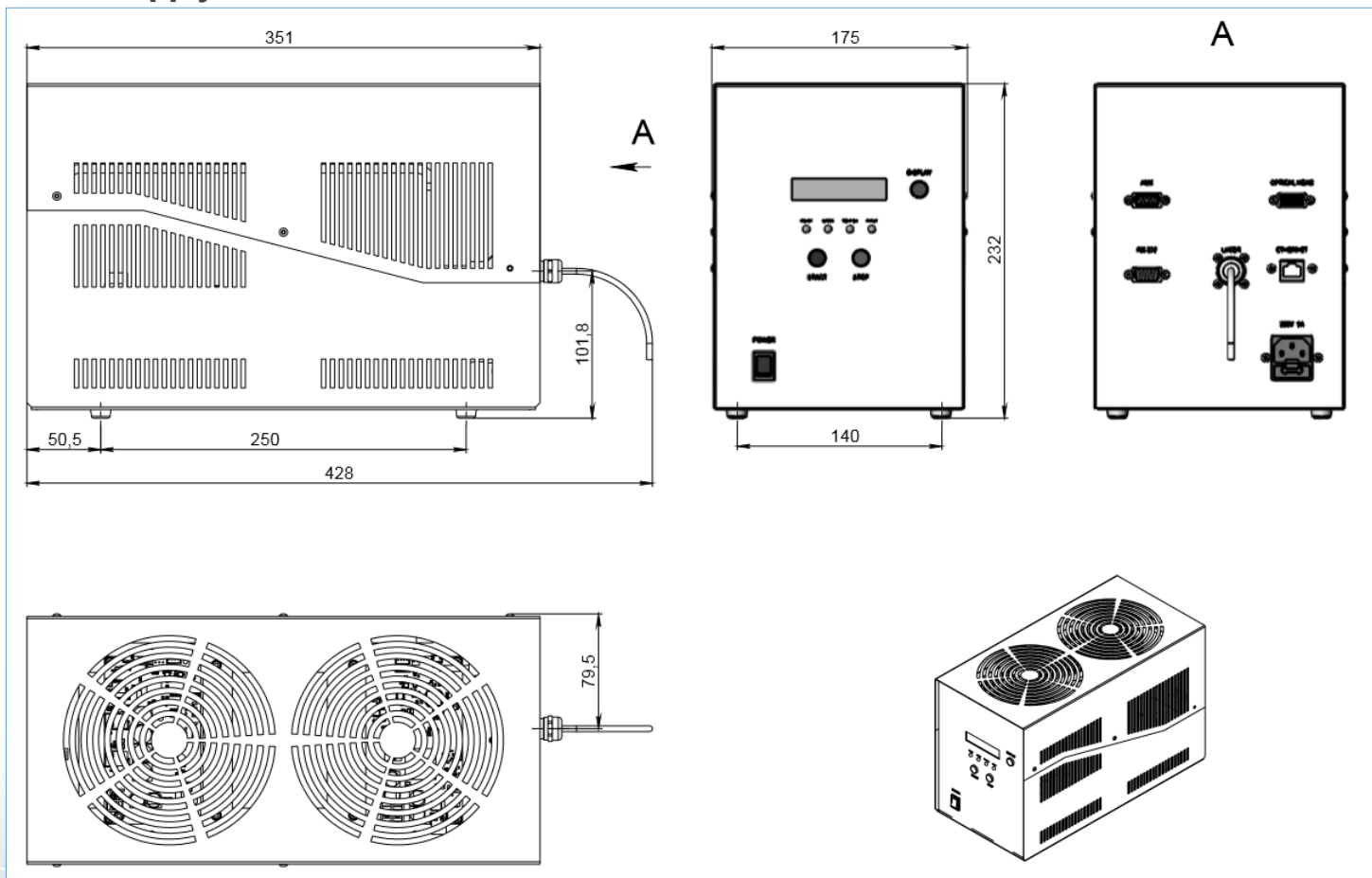

XWS-65 FCU broadband plasma light source

XWS-65 OFR FCU configuration:

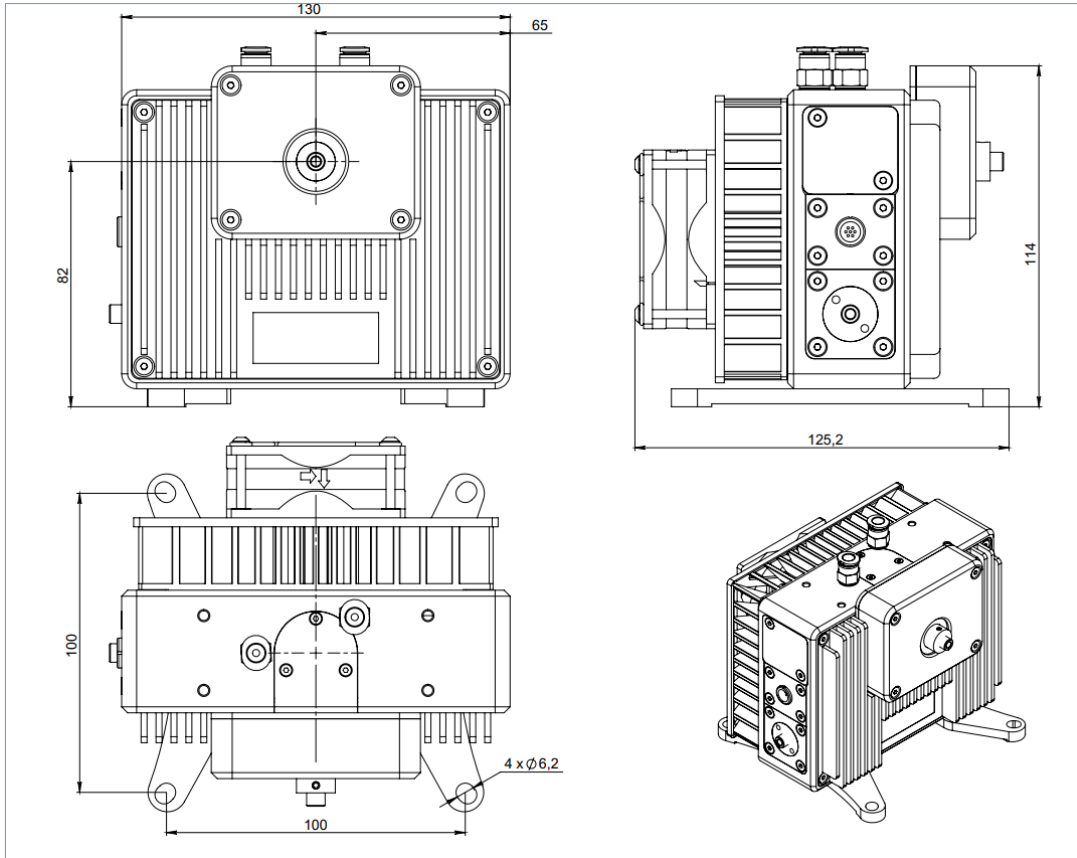

XWS-65 UV FCU configuration:

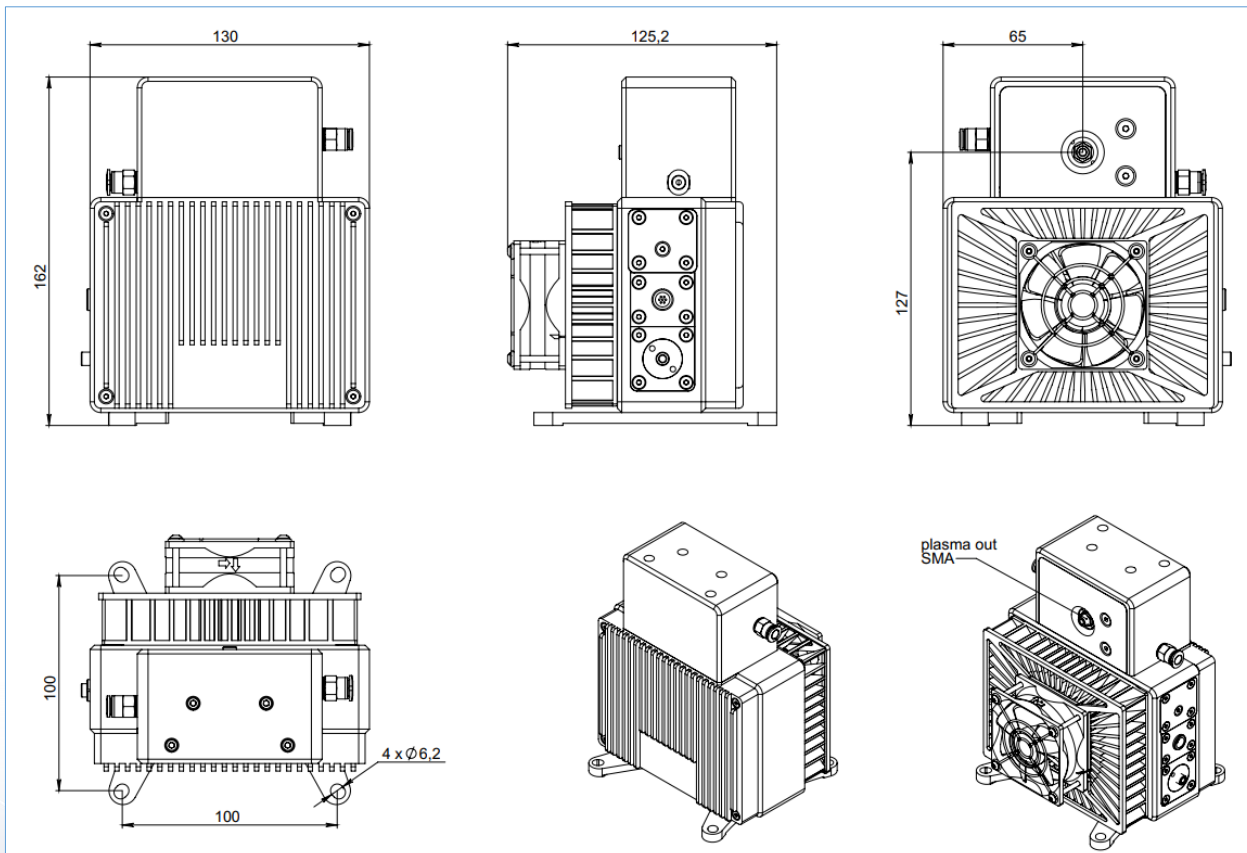

XWS-Dual port: Free space and FCU versions



XWS Dual port Free Space

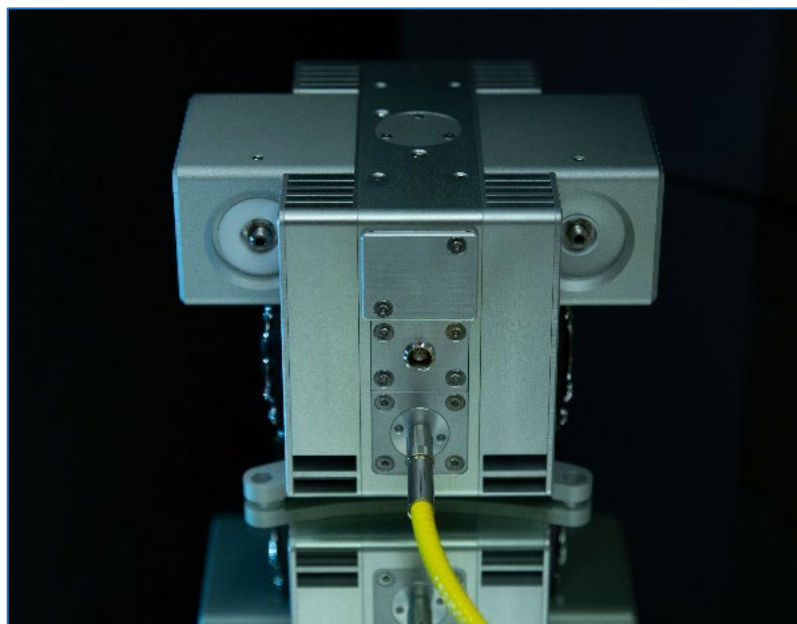

XWS Dual port FCU

Special features:

- Dual beam light source with identical parameters for each port
- Developed on XWS-65 base
- Spectral brightness: up to 50 mW/(mm²·sr·nm)
- High stability: STD <0.15%

FCU version:

- SMA or FC fiber interface
- Output power up to 0.5W after each fiber

Spectral brightness of XWS-Dual port light source in UV and VIS spectral region

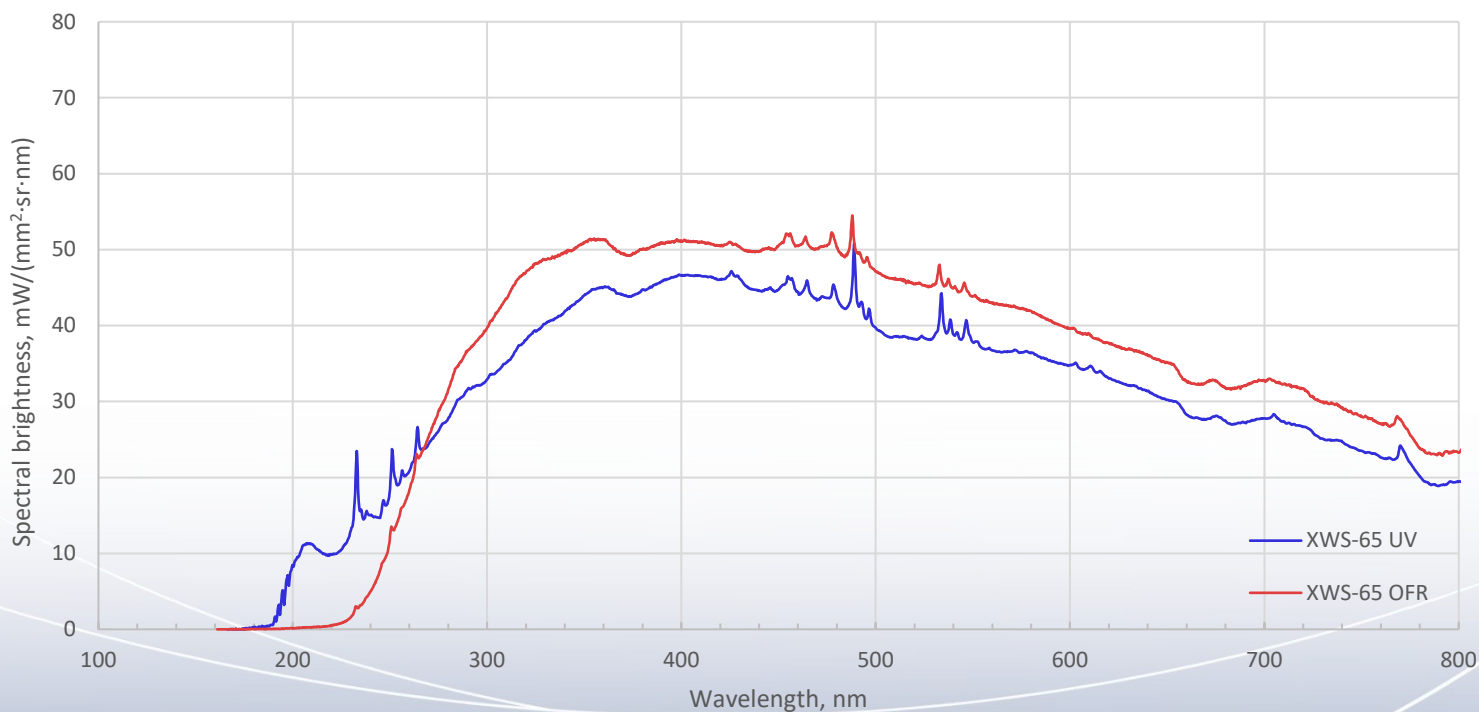

XWS-Dual port: Free space and FCU versions

XWS-Dual port performance

Spectral range	190 - 2500nm for UV configuration, 250 - 2500nm for OFR configuration
Spectral brightness	Up to 50mW/(mm ² ·sr·nm)
Output power	Up to 3 W free space per port Up to 0.5 W via fiber per port
Lamp medium	Xenon
Emitting body size	250×500um
Lifetime	10,000 hours
Temporal and spatial stability	STD < 0.15%

Optical design

Output NA by default	0.4, up to 0.55 upon request
External optic interface by default	C-mount
Optional output interface	Thorlabs SM1, 30mm cage and more
Fiber interface (only for FCU version)	SMA or FC

Optional configurations

Source spectrum	UV or Ozone free
Light output	Free space or fiber coupled
Optical head cooling unit	Air cooling
Power Supply Unit (PSU) cooling system	Air or water cooling

Additional

Connection to PC/Laptop	Ethernet (Web interface), COM-port (RS232)
Interlock	Db-15 connector
Remote plasma control	Db-15 connector

System dimensions and weight

Optical head FCU	130 × 154 × 74mm, 2kg
Power supply unit	351 × 172 × 232mm, 8kg

Facility requirements

Electrical	100-240V, 50/60Hz
Gas purging (only for UV configuration)	Nitrogen or Argon purging, 1l/min

XWS-Dual port FCU

Optical head dimensions:

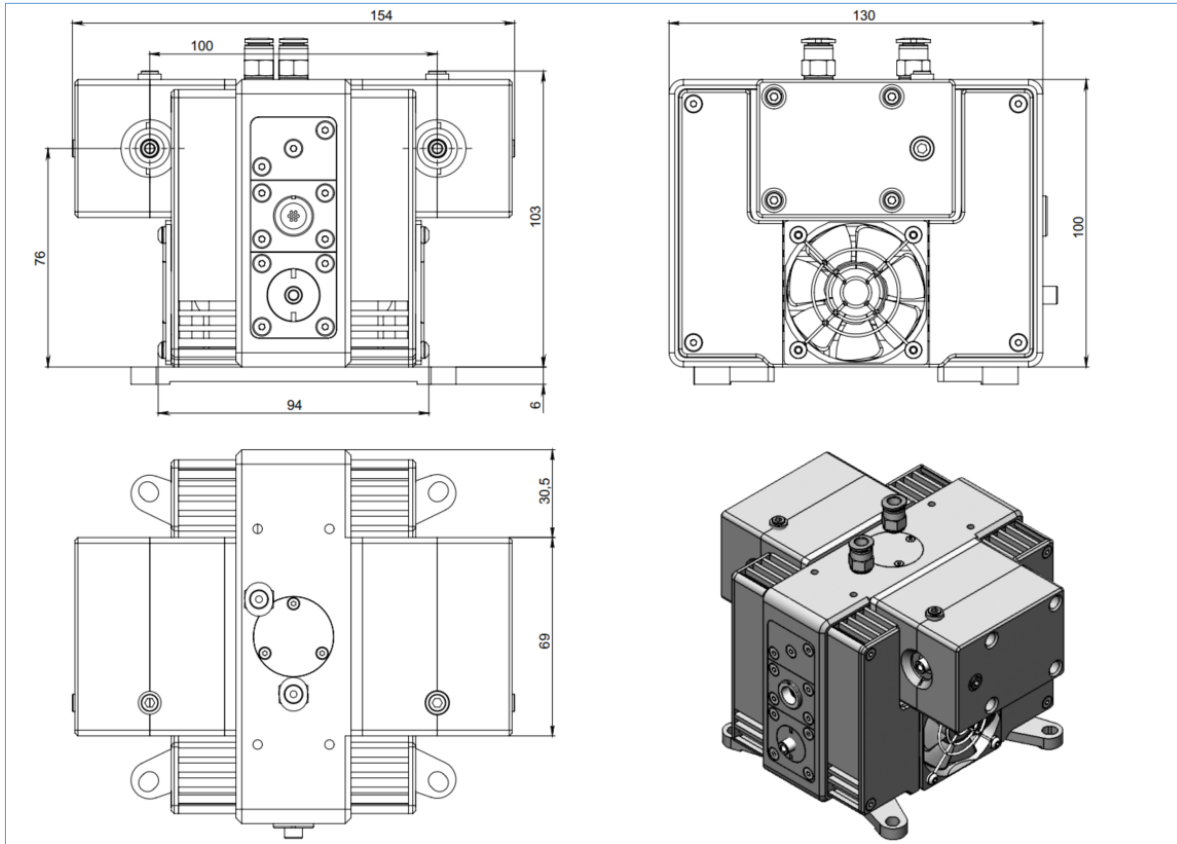

Power Supply Unit (PSU) dimensions:

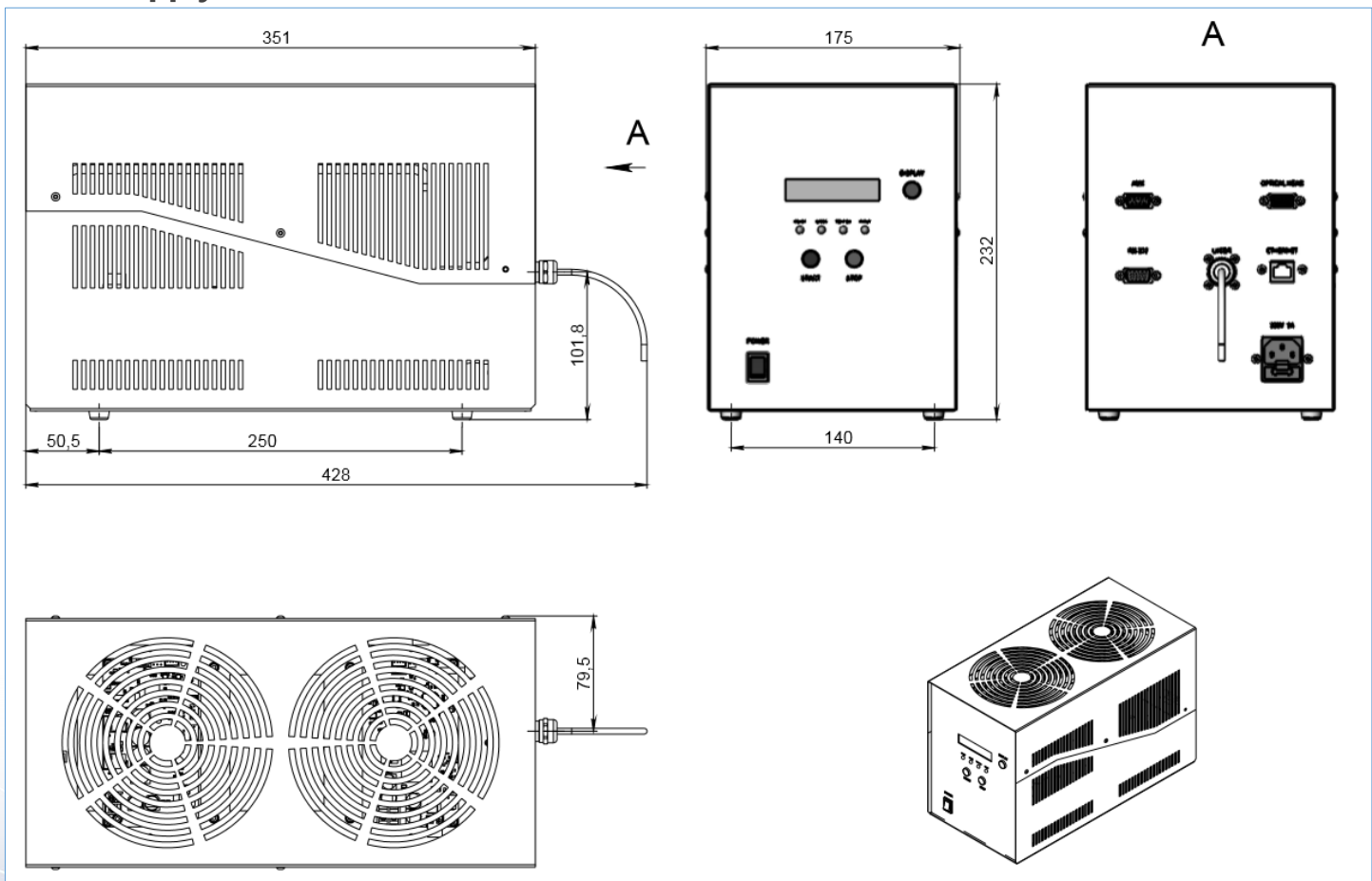

XWS-Dual port Free Space

Optical head dimensions:

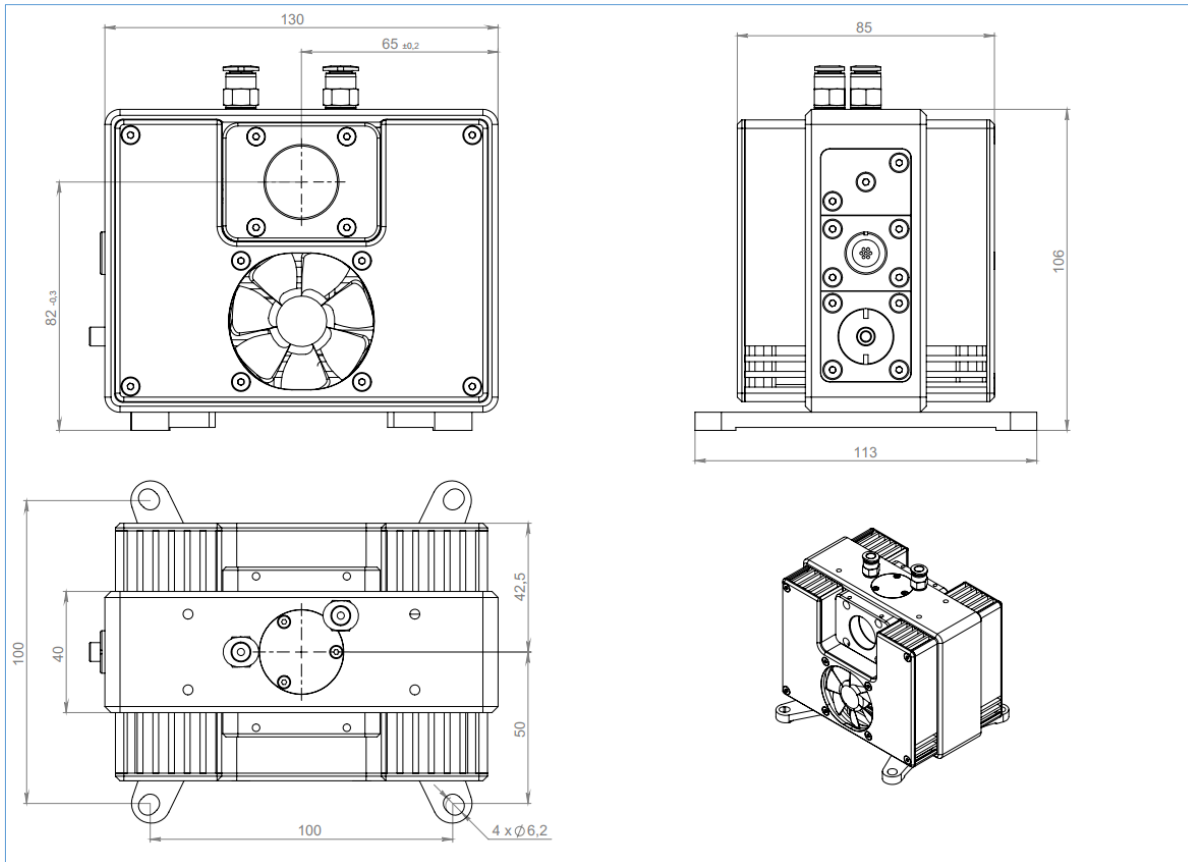

Power Supply Unit (PSU) dimensions:

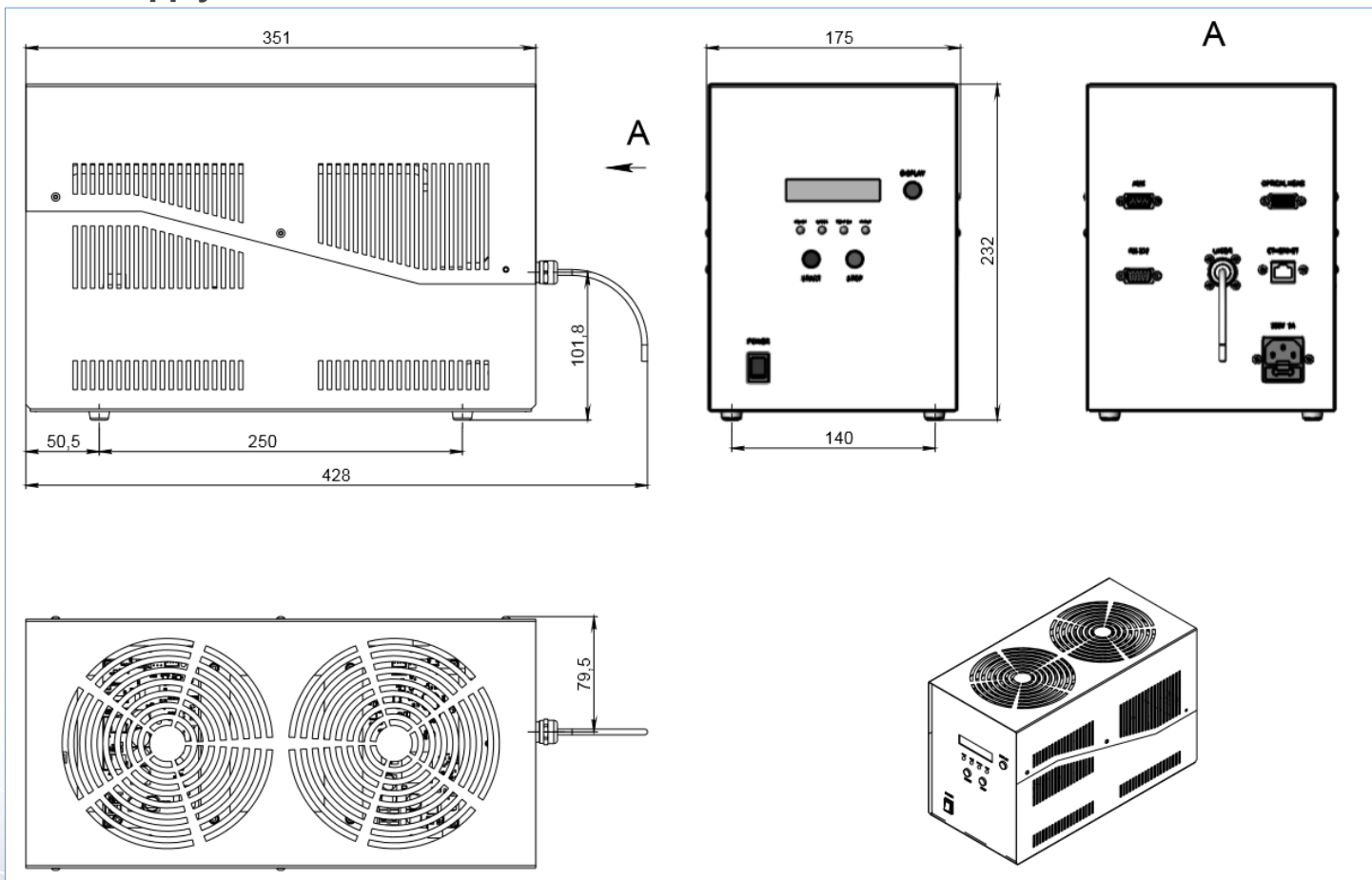

XWS-R high power light source

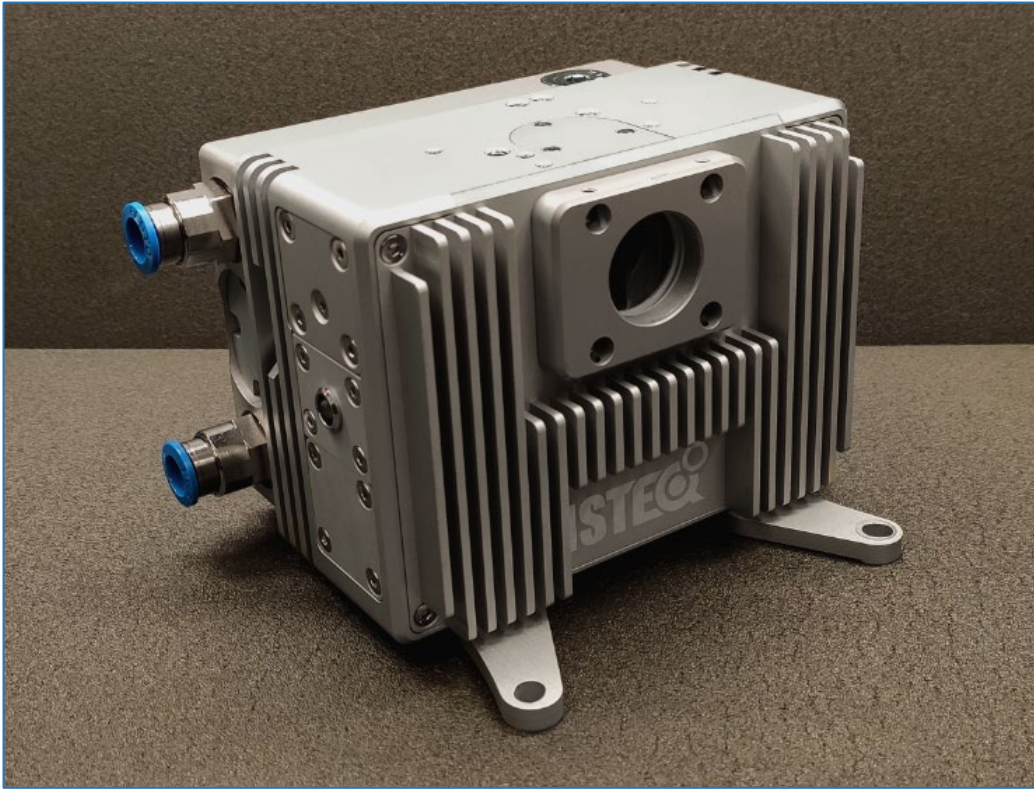

Special features:

- High power version: almost doubled output power/brightness in comparison to default XWS-65
- Spectral brightness: up to 90 mW/(mm²·sr·nm)
- Can be done in both: Free space and FCU configuration
- Up to 1W of output power after a fiber for FCU version

Spectral brightness of XWS-R light source in UV and VIS spectral region

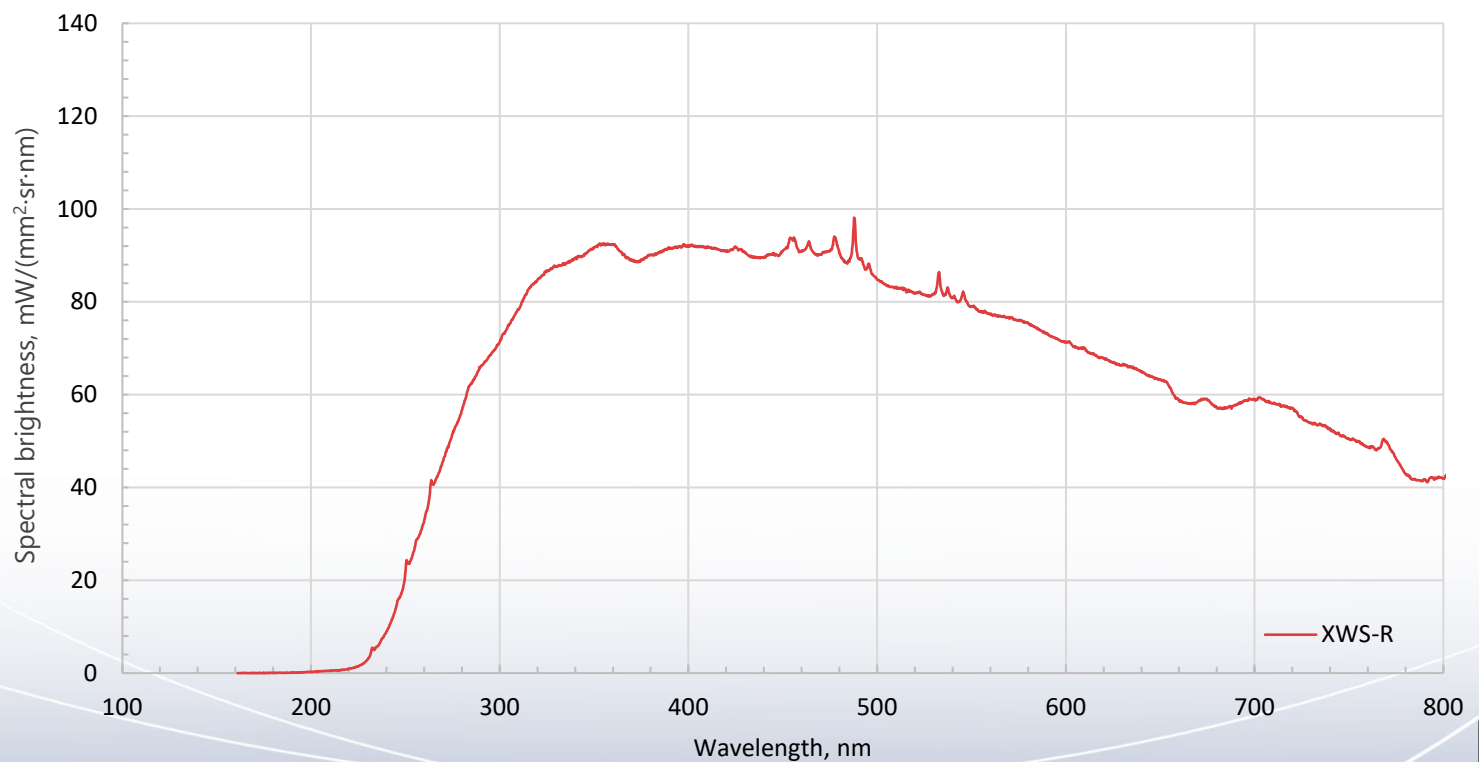

XWS-R high power light source

XWS-R performance

Spectral range	190 - 2500nm for UV configuration, 250 - 2500nm for OFR configuration
Spectral brightness	Up to 90mW/(mm ² ·sr·nm)
Output power	Up to 5 W free space per port Up to 1 W via fiber per port
Lamp medium	Xenon
Emitting body size	250×700um
Lifetime	10,000 hours
Temporal and spatial stability	STD < 0.15%

Optical design

Output NA by default	0.4, up to 0.55 upon request
External optic interface by default	C-mount
Optional output interface	Thorlabs SM1, 30mm cage and more
Fiber interface (only for FCU version)	SMA or FC

Optional configurations

Source spectrum	UV or Ozone free
Light output	Free space or fiber coupled
Optical head cooling unit	Air cooling
Power Supply Unit (PSU) cooling system	Air or water cooling

Additional

Connection to PC/Laptop	Ethernet (Web interface), COM-port (RS232)
Interlock	Db-15 connector
Remote plasma control	Db-15 connector

System dimensions and weight

Optical head FCU	130 × 130 × 74mm, 2kg
Power supply unit	351 × 172 × 232mm, 8kg

Facility requirements

Electrical	100-240V, 50/60Hz
Gas purging (only for UV configuration)	Nitrogen or Argon purging, 1l/min

XWS-R high power light source

Optical head dimensions:

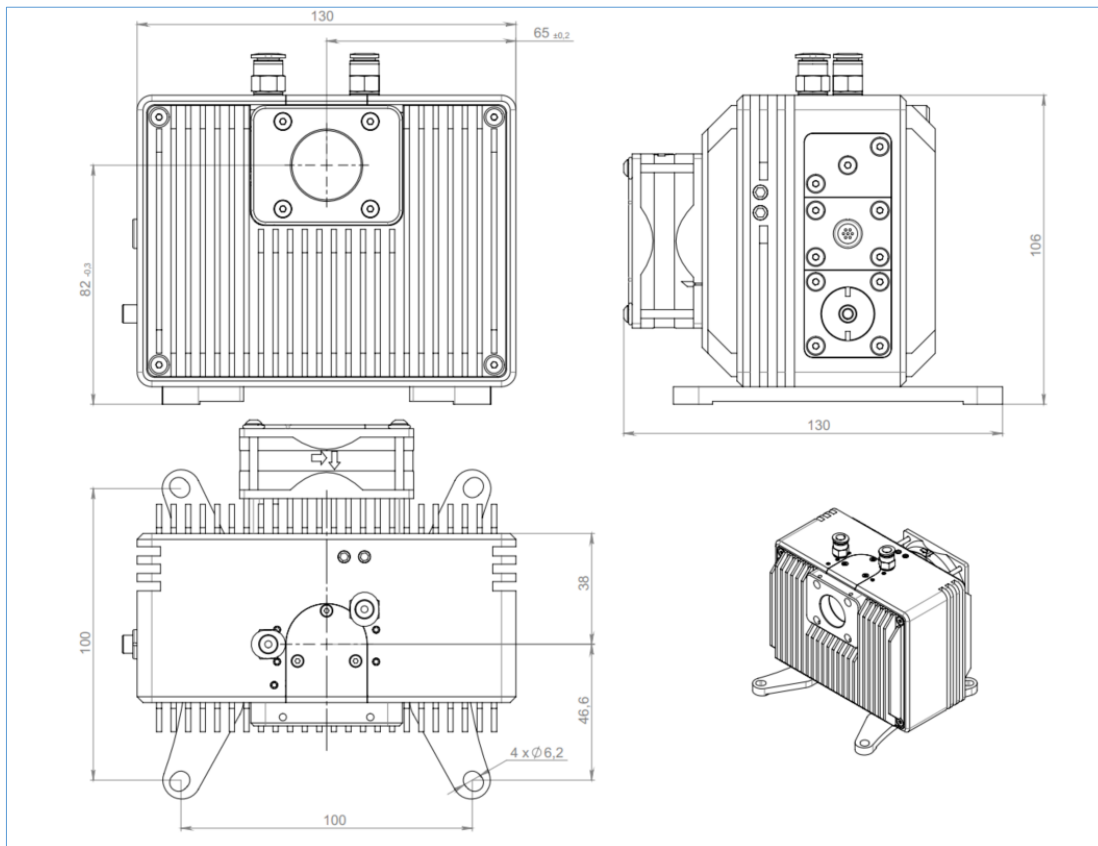

Power Supply Unit (PSU) dimensions:

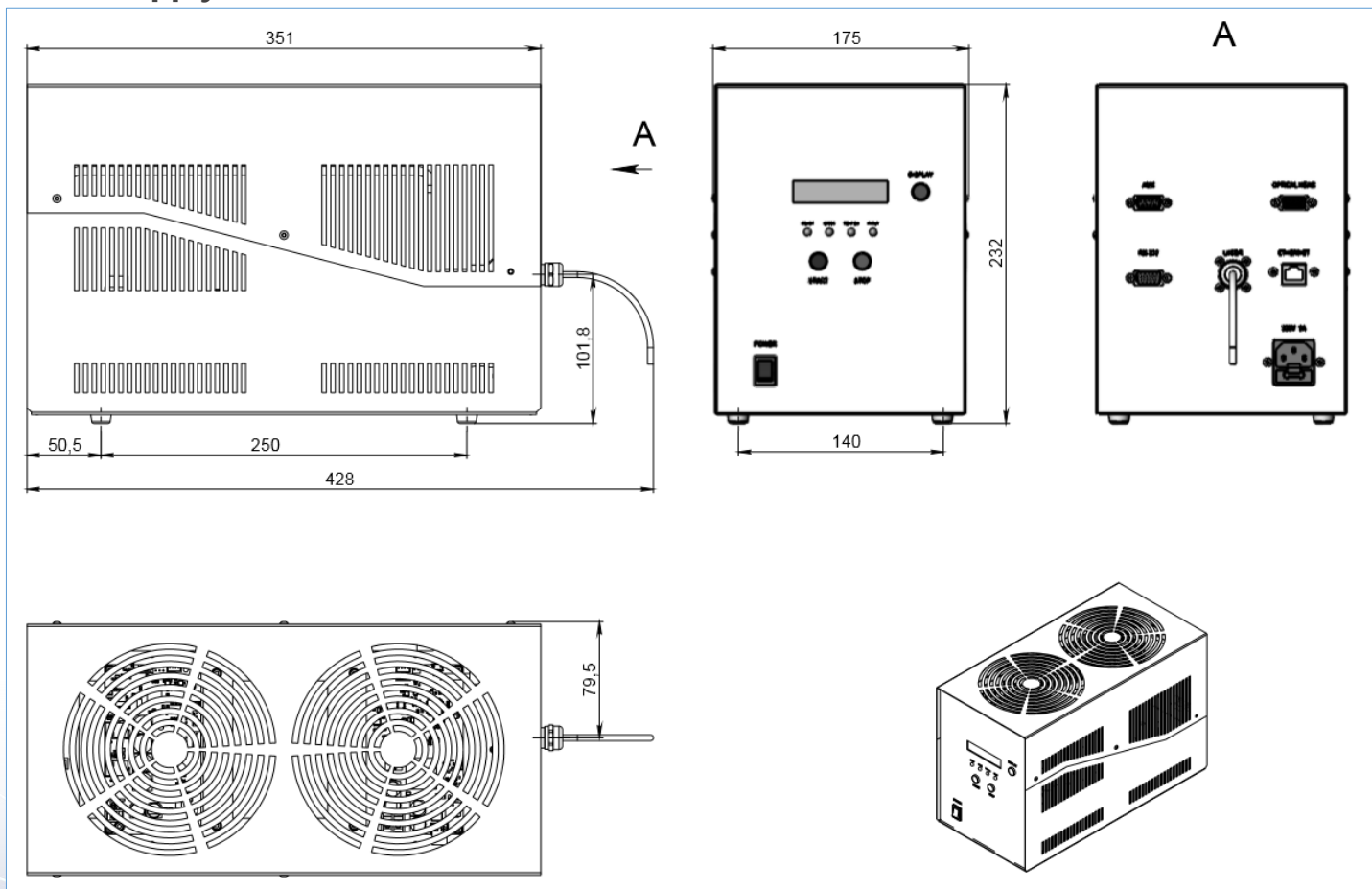

XWS-X high UV light source

ISTEQ's XWS-X light source product has been specially developed for those customers, who needs a powerful light source with a high UV generation.

Special features:

- Significantly higher brightness across the whole spectral range in comparison to XWS-65
- Maximum spectral brightness up to 120mW/(mm²·sr·nm)
- X6 brightness improvement at UV range below 250nm in comparison to XWS-65
- Output configuration: Free space or FCU
- Available in Dual Port configuration
- Available in XR (High power) configuration with a maximum brightness up to 200mW/(mm²·sr·nm)

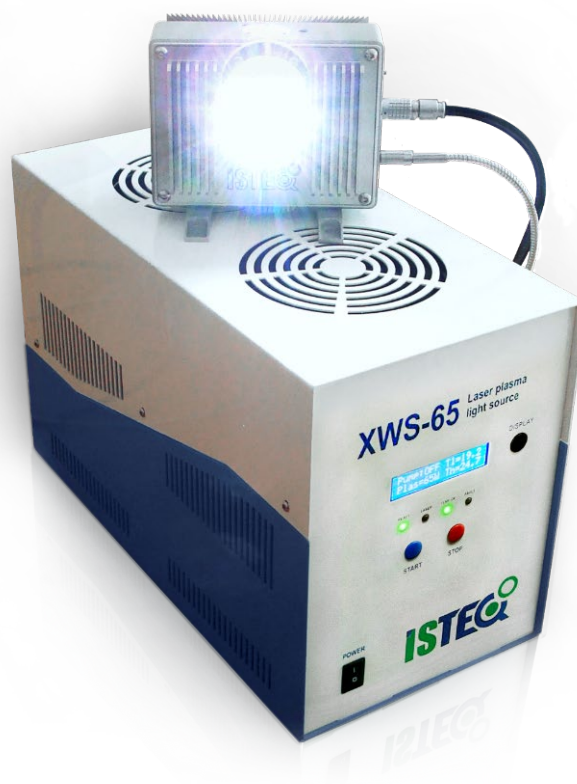

Spectral brightness of XWS-X light source in UV and VIS spectral region

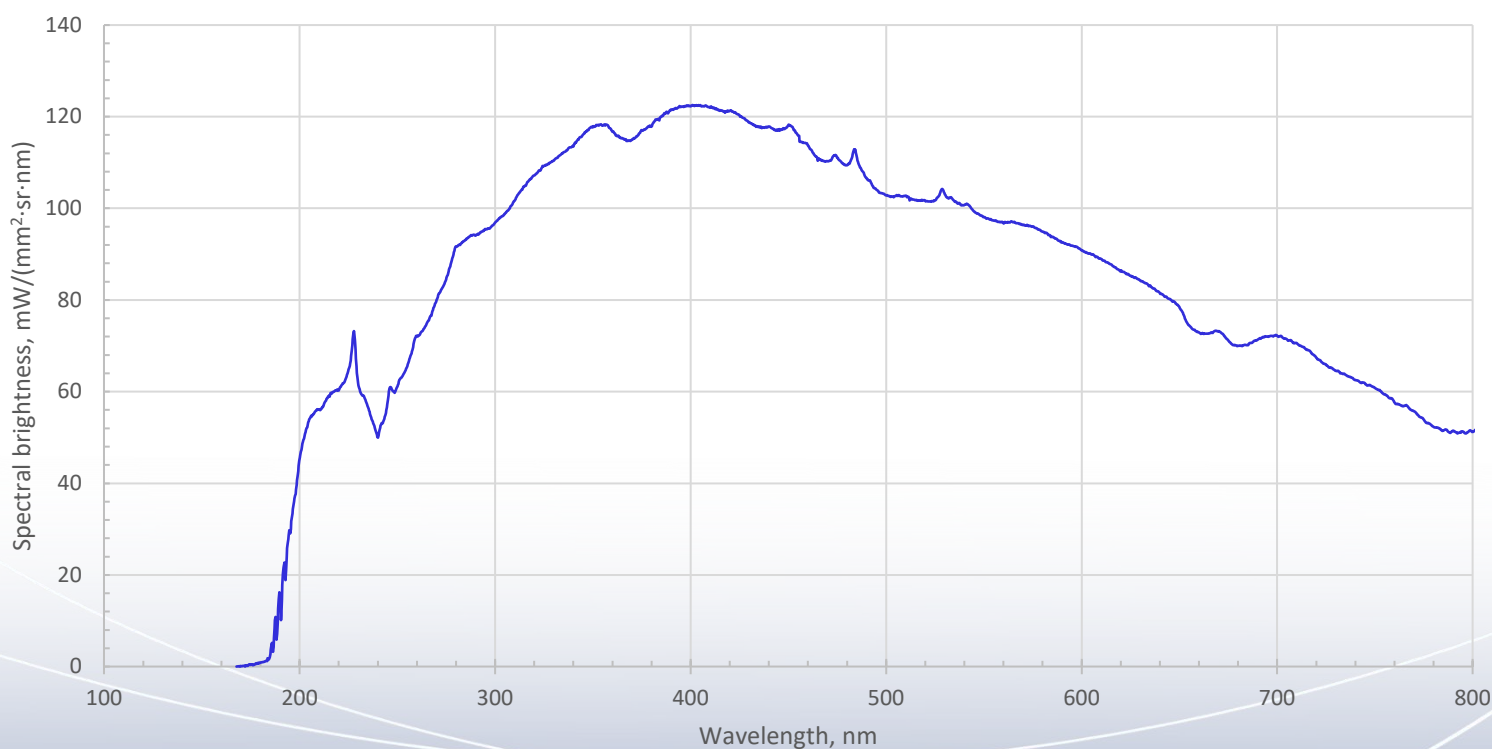

XWS-X high power light source

XWS-X performance

Spectral range	190 - 2500nm for UV configuration, 250 - 2500nm for OFR configuration
Spectral brightness	Up to 120mW/(mm ² ·sr·nm)
Output power	Up to 3 W free space Up to 0.6 W via fiber
Lamp medium	Xenon
Emitting body size	250×500um
Lifetime	10,000 hours
Temporal and spatial stability	STD < 0.15%

Optical design

Output NA by default	0.4, up to 0.55 upon request
External optic interface by default	C-mount
Optional output interface	Thorlabs SM1, 30mm cage and more
Fiber interface (only for FCU version)	SMA or FC

Optional configurations

Source spectrum	UV or Ozone free
Light output	Free space or fiber coupled
Optical head cooling unit	Air cooling
Power Supply Unit (PSU) cooling system	Air or water cooling

Additional

Connection to PC/Laptop	Ethernet (Web interface), COM-port (RS232)
Interlock	Db-15 connector
Remote plasma control	Db-15 connector

System dimensions and weight

Optical head FCU	130 × 110 × 74mm, 1.8kg
Power supply unit	351 × 172 × 232mm, 8kg

Facility requirements

Electrical	100-240V, 50/60Hz
Gas purging (only for UV configuration)	Nitrogen or Argon purging, 1l/min

XWS-X broadband plasma light source

Optical head (Free Space) dimensions:

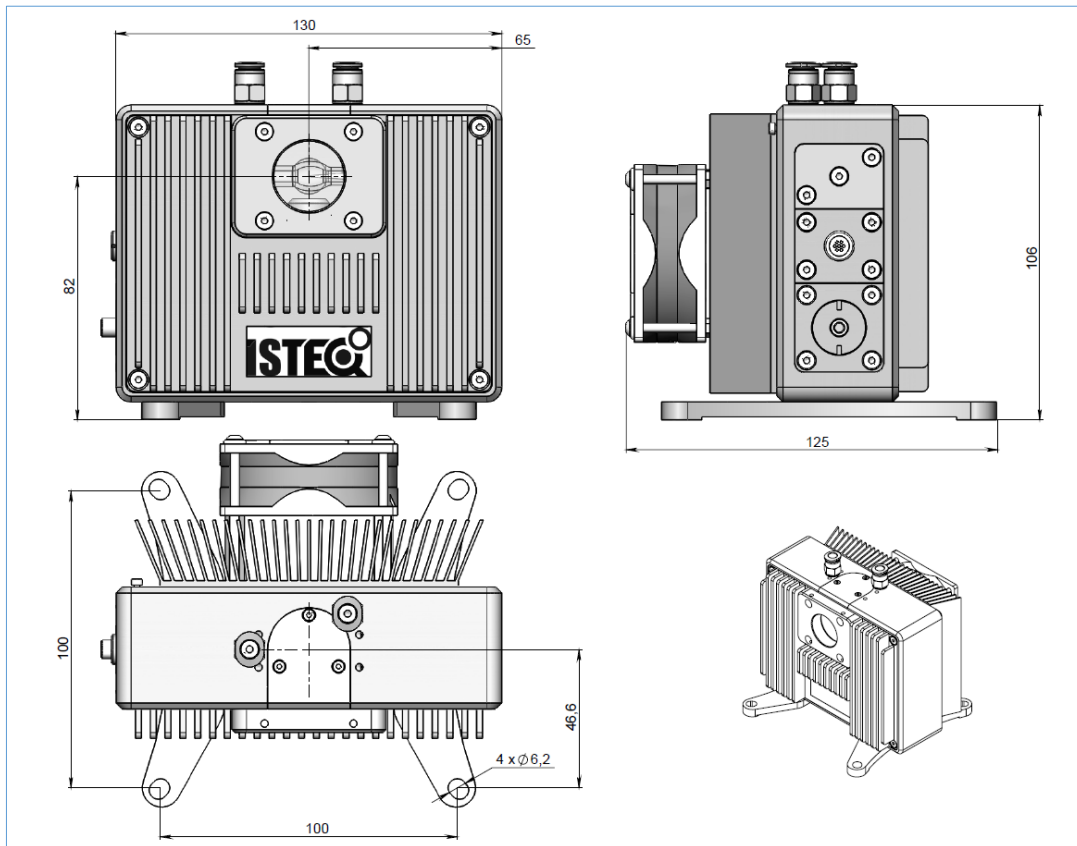

Power Supply Unit (PSU) dimensions:

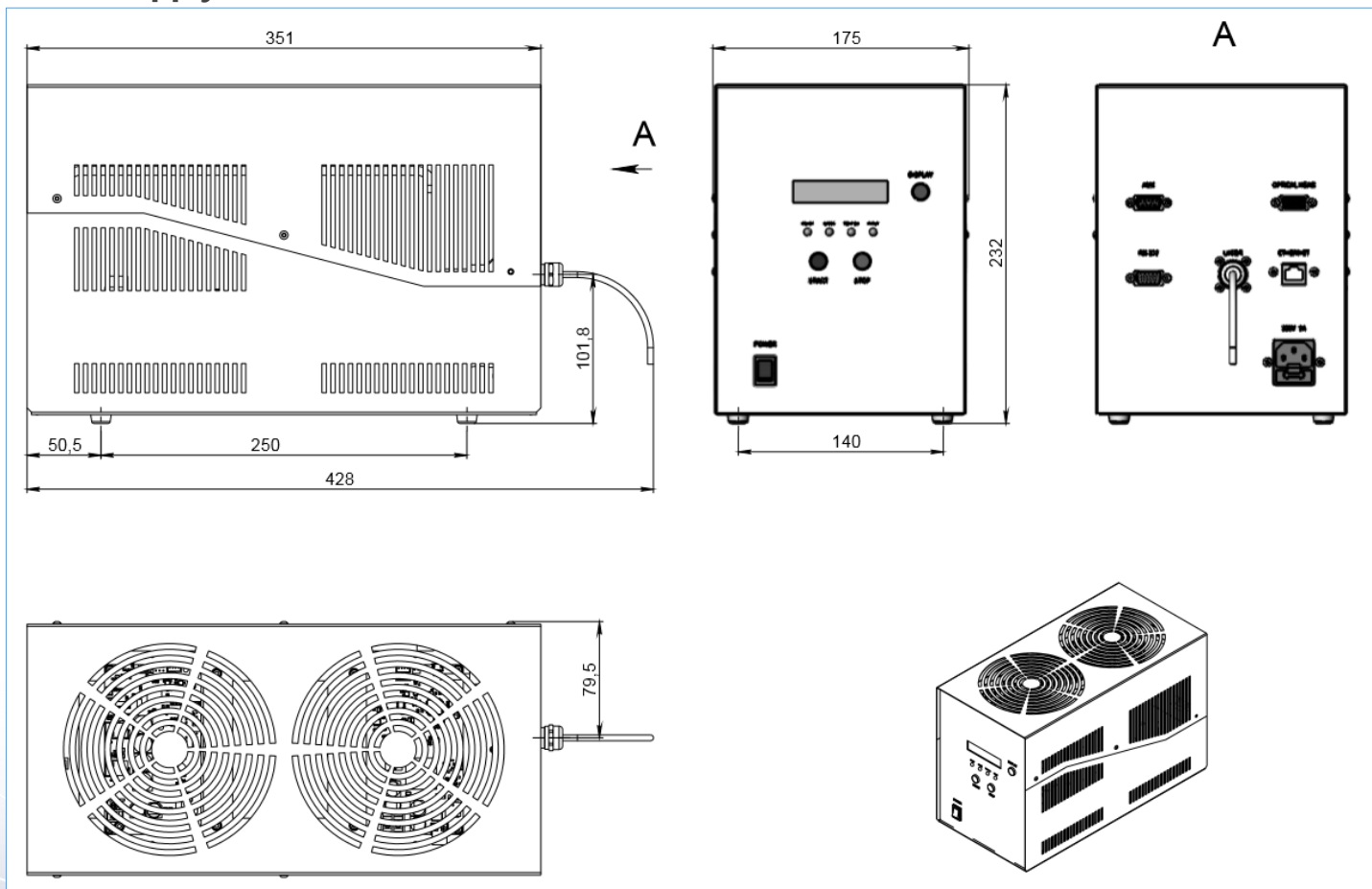

XWS-30 compact light source



ISTEQ's XWS-30 light source product has been specially developed for those customers, who needs super compact broadband light source with low heat dissipation, keeping the plasma brightness high.

Special features:

- Unique concept of a compact **"all in one"** source
- Very compact: 110x110x120mm, no external chiller
- Spectral brightness: up to 40 mW/(mm²·sr·nm)
- Output configuration: Free space or FCU
- Full system control by Laptop/PC via USB-RS485 adapter

Spectral brightness of XWS-30 light source in UV and VIS spectral region



XWS-30 high power light source

XWS-30 performance

Spectral range	190 - 2500nm for UV configuration, 250 - 2500nm for OFR configuration
Spectral brightness	Up to 40mW/(mm ² ·sr·nm)
Output power	Up to 1.5 W free space Up to 0.4 W via fiber
Lamp medium	Xenon
Emitting body size	100×200um
Lifetime	10,000 hours
Temporal and spatial stability	STD < 0.15%

Optical design

Output NA by default	0.5, up to 0.55 upon request
External optic interface by default	C-mount
Optional output interface:	Thorlabs SM1, 30mm cage and more
Fiber interface (only for FCU version)	SMA or FC

Optional configurations

Source spectrum	UV or Ozone free
Light output	Free space or fiber coupled
Optical head cooling unit	Air cooling

Additional

Connection to PC/Laptop	COM-port (RS485) or USB
Interlock	Lemo FG

System dimensions and weight

Optical head	110 × 110 × 120mm, 2kg
--------------	------------------------

Facility requirements

Electrical	100-240V, 50/60Hz
Gas purging (only for UV configuration)	Nitrogen or Argon purging, 1l/min

XWS-30 compact light source

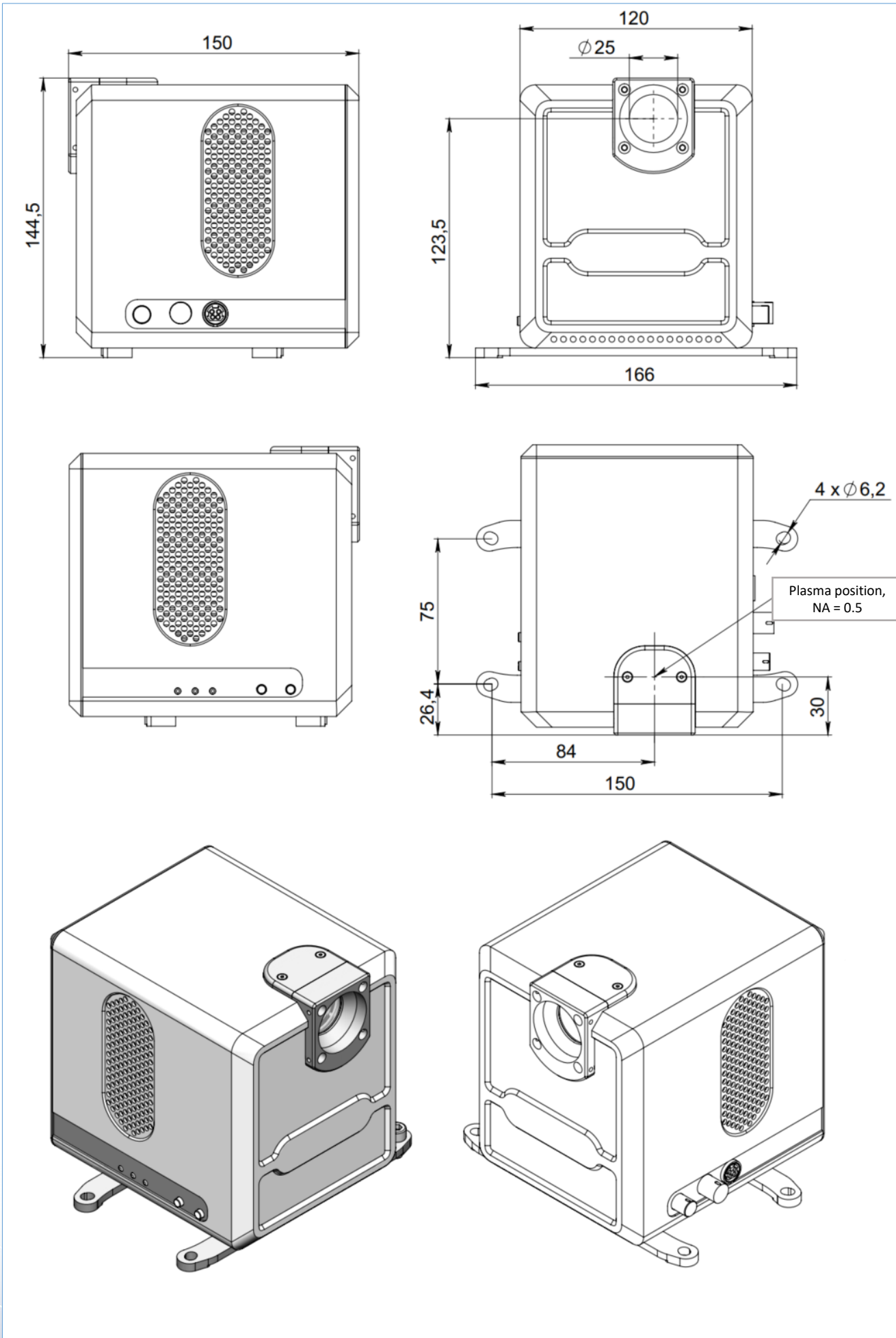

XWS specifications

	XWS-30	XWS-65	XWS-R	XWS-X
Spectral range for UV/OFR:	190 - 2500nm / 250 - 2500nm			
Maximum spectral brightness	40mW/(mm ² ·nm·sr)	50mW/(mm ² ·nm·sr)	90mW/(mm ² ·nm·sr)	120mW/(mm ² ·nm·sr)
Output power	Up to 1.5W free space Up to 0.4W via fiber	Up to 3W free space Up to 0.5W via fiber	Up to 5W free space Up to 1W via fiber	Up to 3W free space Up to 0.6W via fiber
Emitting body size	100×200um	250×500um	250×700um	250×500um
Lifetime	10,000 hours			
Temporal and spatial stability	STD < 0.15%			
Optical design				
Output NA (by default)	0.5	0.4	0.4	0.4
Maximum NA (upon request)	0.55			
External optic interface	C-mount, 30 Thorlabs cage			
Optional configurations				
Source spectrum	UV or Ozone free			
Light output	Free space or fiber coupled			
Additional features				
External control	COM-port (RS-485)	COM-port (RS-232)		
Interlock / Distant plasma control	Lemo FGG	Db-15 connector		
Dimensions				
Optical head dimensions	138x110x148mm	130x75x106mm	130x110x106mm	130x75x106mm
Power supply dimensions	NA (No power supply)	351x175x232mm	351x175x232mm	351x175x232mm

Available configurations

	Output configuration		Cooling system			
	Dual Port Output	UV/OFR FCU	Water Cooled Optical Head	Air Cooled PSU	Water Cooled PSU	Air Cooled PSU
XWS-30	✗	✓	✗	✓	N/A	N/A
XWS-65	✓	✓	✓	✓	✓	✓
XWS-R	✗	✓	✓	✓	✓	✓
XWS-X	✓	✓	✓	✓	✓	✓
XWS-XR	✗	✓	✓	✓	✓	✓

Custom design

Upon a request that is possible to modify ISTEQ serial product to meet customer requirements.

Hyperchromator – tunable light source



The Hyperchromator - «Mountain Instruments» monochromator designed by for ISTEQ's laser-pumped plasma light source XWS-30. The Hyperchromator optimally uses the advantages of the pointed plasma light source by using a mirror with an aperture up to f/1.5 to collect the light and ensure maximum light throughput without a limiting entrance slit. It is optimized for applications that require a fast and tunable point light source.

Special features:

- Different configurations available
- Fast optics, up to f/1.5 for highest throughput
- Homogenous output distribution due to a proprietary design
- Etendue-matched to ISTEQ XWS-30
- Broad tunable range from DUV to NIR
- No input slit
- Built-In Shutter
- Easy to use Software, Windows GUI
- LabView integration upon request

Power Hyperchromator II 400 μ m fiber with NA=0.22

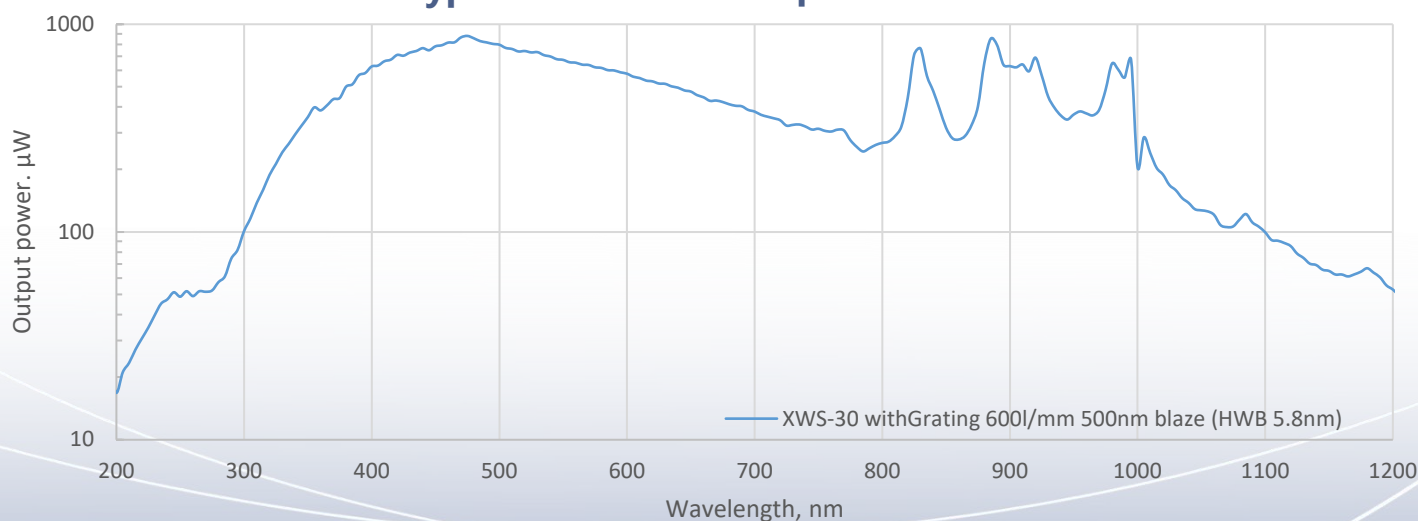

Hyperchromator – tunable light source

Hyperchromator performance

Optical input	ISTEQ XWS-30 light source, directly coupled (optionally other sources)
Optical output	Fused silica fiber, SMA or FC, 100-600 μm core or free beam output with adjustable slit or various collimator options. Spectral power monitoring on request.
Wavelength range	185 – 2500 nm*
Aperture	f/1.5 or f/2 (depending on required resolution and light output)
Bandwidth	1-10 nm FWHM*
Output power	Up to 800 μW (grating at blaze wavelength, 6 nm bandwidth and 400 μm fiber)
Reproducibility	0.1 nm
Scanning speed	40-100 nm/s*
Control interface	USB/RS-232, LabVIEW™-based GUI, various external control options
Dimensions and Weight	47 x 45 x 25cm (WxDxH); 16kg

*: depends on choice of gratings and other requirements

Distributors

Germany

«Mountain Photonics GmbH»
Address: Albert-Einstein-Str. 18, 86899 Landsberg
am Lech
Phone: +49 (0)8191 985199-0
E-Mail: m.rotschaedl@mphotronics.de
Website: www.mountainphotonics.de



France

«Optoprim S.A.S.»
Address: 21-23 rue Aristide Briand, 92170 VANVES,
Manager: François Beck
Phone: +33(0)141903377
E-mail: fbeck@optoprim.com
Website: www.optoprim.com



Italy

«Optoprim S.R.L.»
Address: Via Monte Giberto, 1500138 Roma
Phone: (+39)-06-87657838
Mobile: (+39)-342-3764819
E-Mail: ventura@optoprim.it
Website: www.optoprim.it



Israel

«IL Photonics BSD Ltd.»
Address: 511 Hashita, Beit Shemesh 995256, Israel
Manager: Moshe Bril
Phone: +972-77-3240205; Mobile: +972- 54-
7309940
E-mail: moshe@il-photonics.com
Website: www.ilphotonics.com



South Korea

«Laser Spectronix»
Address: #406, 219, Gasan digital 1-ro,
Geumcheon-gu, Seoul 08501, Korea
Manager: Kilhwan Jeon
Phone: +82-2-2627-3123; Mobile: +82-10-8797-
8357
E-mail: kilhwan.jeon@laser.co.kr
Website: www.laser.co.kr



Japan

«KLV CO. LTD»
Address: 1-1 Kanda Ogawamachi, Chiyoda-ku,
Tokyo 101-0052
Manager: Yoshihiro Higano
Phone: +81-3-3258-1238
E-mail: higano@klv.co.jp
Website: www.klv.co.jp



Taiwan

«Forter Technology Corporation»
Address: 5F., #758, Zhongming S.Rd., South Dist.,
Taichung City 40255, Taiwan (R.O.C.)
Manager: James Chien
Phone: +886-422-607729 ext: 31
Mobile: +886-933-503818
Mail: james@forter.com.tw
Website: www.forter.com.tw



Singapore

«Precision Technologies»
Address: 211 Henderson Road #13 - 02 Henderson
Industrial Park Singapore 159552
Phone: +65-6273-4573
Email: precision@pretech.com.sg
Website: www.pretech.com.sg



PRECISION TECHNOLOGIES

Contacts

ISTEQ B.V. is located in the High Tech Campus Eindhoven which is famous as the "[smartest km²](#)" in The Netherlands. The campus holds more than 125 companies and institutes with more than 10,000 researchers, developers and entrepreneurs working on developing future cutting edge technologies and products.

ISTEQ B.V.

Address: High Tech Campus 9, 5656AE
Eindhoven, The Netherlands

Phone: +314-0230-42-42

Mobile: +316-2525-7382

E-mail: info@isteq.nl

Website: www.isteq.nl



OPTOPRIM

Monza (+39) 039.834.997

Roma (+39) 06.8765.7838

www.optoprim.it info@optoprim.it