

Silicon Avalanche Photodiode SAR1500x/SAR3000x

The SAR1500/3000x is based on a “reach-through” structure for excellent quantum efficiency and high speed. TO-5 and TO-8 package options are available.

These APDs are also available in a hermetically sealed TO-37 with thermoelectrical cooler. This enables the APD to be used in a variety of demanding applications including fluorescence detection, LIDAR and medical applications.

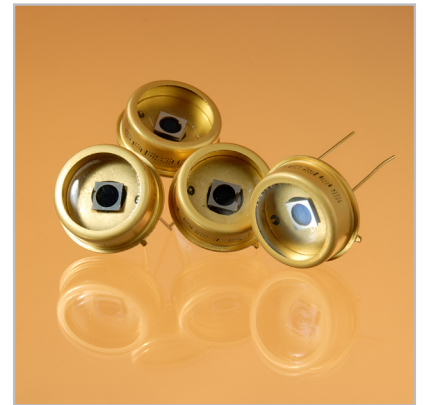

Features

- Very high quantum efficiency
- Low noise, high speed
- Multiplication gain, $M > 100$ available
- 1.5 mm / 3.0 mm diameter active area
- Gradual multiplication curve
- Wide operating temperature range

Applications

- Medical
- Fluorescence detection
- LIDAR
- Analytical

Generic Characteristics at $T_a = 25\text{ }^\circ\text{C}$

	SAR1500x			SAR3000x			Units
	Min	Typ	Max	Min	Typ	Max	
Wavelength range	400		1000	400		1000	nm
Peak sensitivity		890			890		nm
Diameter		1500			3000		μm

Absolute Maximum Ratings

	SAR1500x/SAR3000x		Units
	Min	Max	
Storage temperature	-55	100	°C
Operating temperature	-40	85	°C
Reverse current Peak value (CW operation)		200	µA
Reverse current Peak value (1 sec duration)		1	mA
Forward current I_F at 25 °C, average value (CW operation)		5	mA
Forward current I_F at 25 °C, peak value (1 sec duration)		50	mA
Max. total power dissipation		60	mW
Soldering (for 15 sec.)		260	°C

Electrical Characteristics, $T_a = 25\text{ °C}$, $M = 100$

	SAR1500x			SAR3000x			Units
	Min	Typ	Max	Min	Typ	Max	
Breakdown voltage @ $I_d = 10\text{ µA}$	150	270	400	150	270	400	Volt
Responsivity @ 905 nm		50			50		A/W
V_{br} temperature coefficient		1	3.2		1	3.2	V/°C
Dark current		1	5		3	10	nA
Noise current		2.5			5		pA/sqrt Hz
Capacitance		4			7		pF
Rise time		500			800		psec

Curves

Fig. 1: Spectral Response @ M = 100

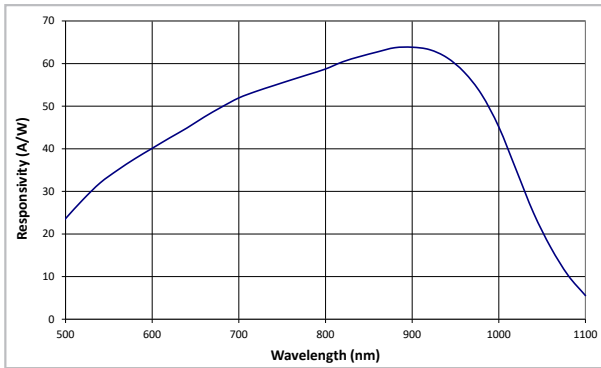

Fig. 2: Quantum Efficiency vs. Wavelength

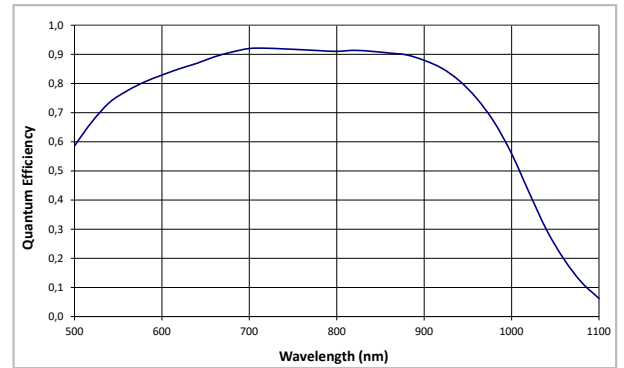

Fig. 3: Typical Dark Current Characteristics

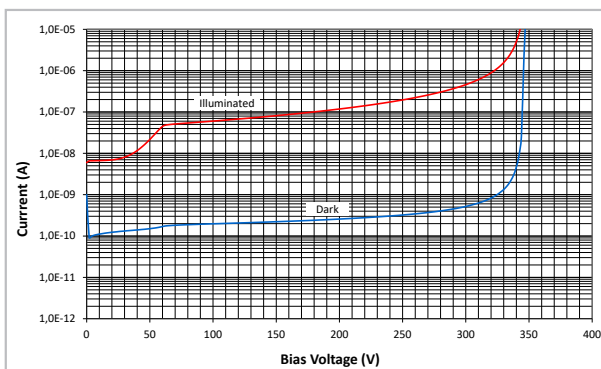

Fig. 4: Gain - Voltage Characteristics @ 905 nm

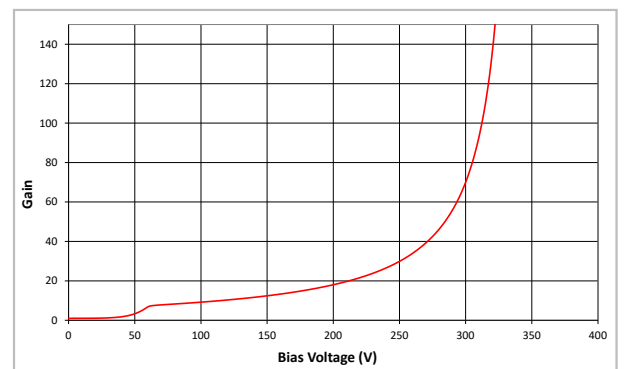

Fig. 5: Capacitance vs. Reverse Voltage

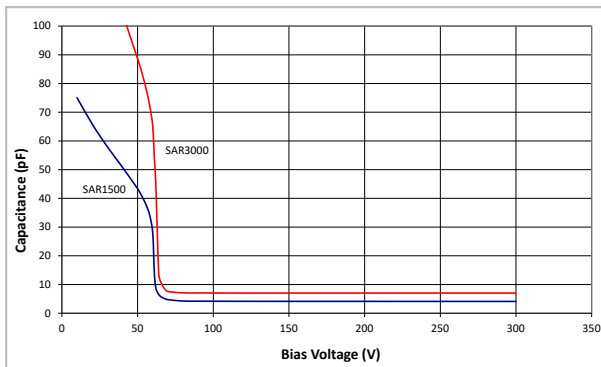
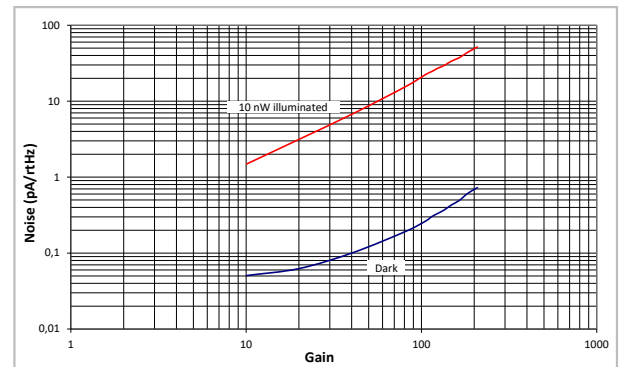
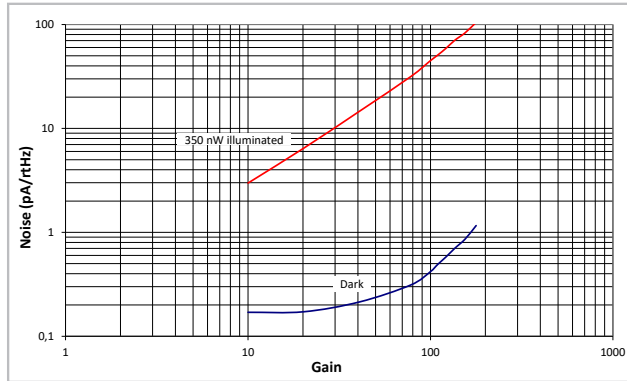

Fig. 6: Typical APD Noise Density as a Function of Gain for SAR1500x



01/20 / V13 / IF / Icapad/sar1500-3000x

Fig. 7: Typical APD Noise Density as a Function of Gain for SAR3000x



Product Number Designations

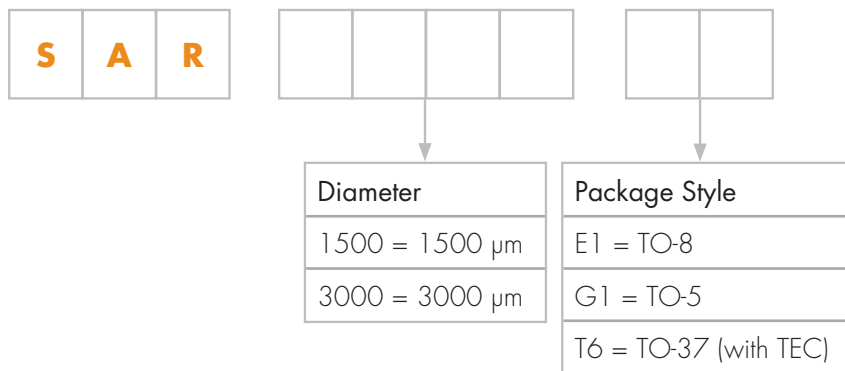

Package Drawings

Package E1 TO-8

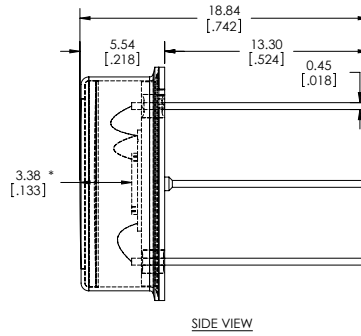
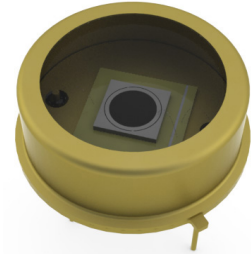

* DISTANCE FROM TOP OF DEVICE TO TOP OF DETECTOR

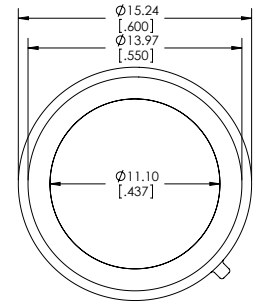

PIN #1: Cathode
PIN #2: Ground/Case
PIN #3: Anode

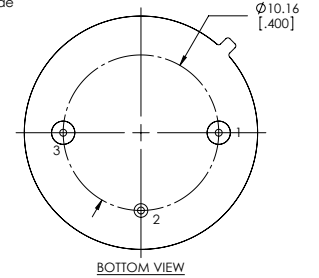

Package G1 TO-5

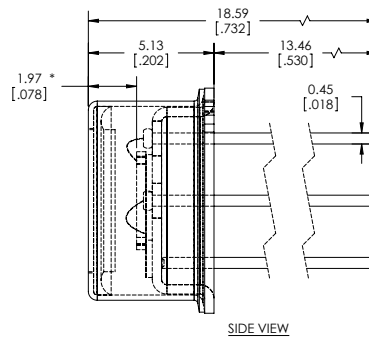
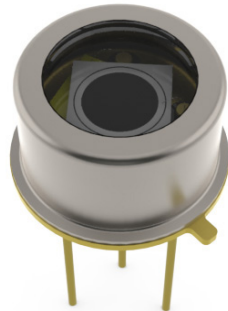

* DISTANCE FROM TOP OF DEVICE TO TOP OF DETECTOR

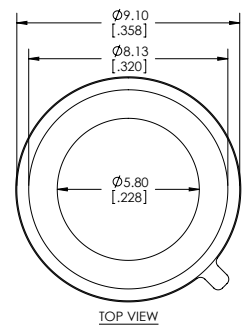

PIN #1: Cathode
PIN #2: Anode
PIN #3: Ground/Case

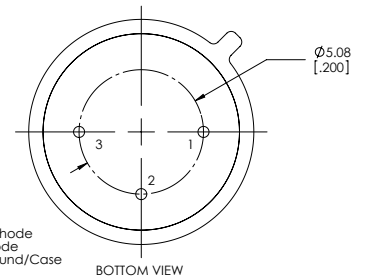

Package T6 TO-37 (with TEC)

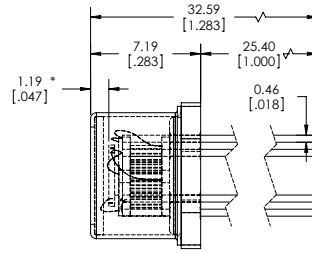
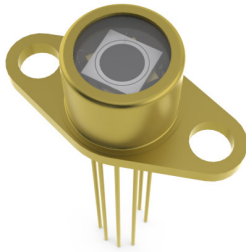

SIDE VIEW

* DISTANCE FROM TOP OF DEVICE TO TOP OF DETECTOR

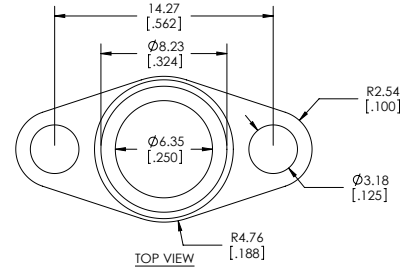

TOP VIEW

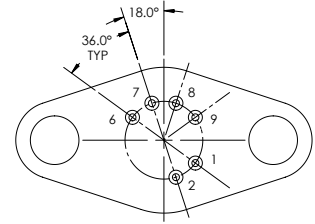

BOTTOM VIEW

PIN #1: Thermistor
PIN #2: Thermistor
PIN #6: Anode
PIN #7: Cathode
PIN #8: TEC -
PIN #9: TEC +

Product Changes

LASER COMPONENTS reserves the right to make changes to the product(s) or information contained herein without notice.

No liability is assumed as a result of their use or application.

Ordering Information

Products can be ordered directly from LASER COMPONENTS or its representatives. For a complete listing of representatives, visit our website at www.lasercomponents.com

Custom designed products are available on request.