

Silicon Avalanche Photodiode SAE-Series (Red-Enhanced)

Description

The SAE230VS and SAE500VS epitaxial avalanche photodiodes are general purpose APD with high responsivity and extremely fast rise and fall times through out the 400 to 1000 nm wavelength range. The peak responsivity at 650 nm is ideally suited to rangefinding applications using visible laser diodes. A variety of package options are available.

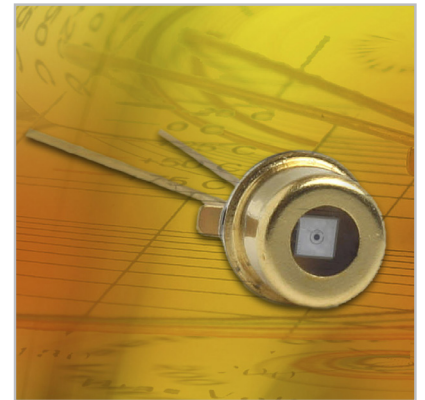

Features

- High quantum efficiency
- Low noise, high speed
- Multiplication gain, $M > 100$ available
- 500 μm diameter active area
- Gradual multiplication curve
- Wide operating temperature range

Applications

- Rangefinding
- Optical communication systems

Generic Characteristics at $T = 25^\circ\text{C}$

	SAE230VX			SAE500VX			Units
	Min	Typ	Max	Min	Typ	Max	
Wavelength range	400		1000	400		1000	nm
Peak sensitivity		650			650		nm
Diameter		230			500		μm

Absolute Maximum Ratings

	SAE230VX		SAE500VX		Units
	Min	Max	Min	Max	
Storage temperature	-55	100	-55	100	°C
Operating temperature*	-40	85	-40	85	°C
Reverse current Peak value (CW operation)		200		200	µA
Reverse current Peak value (1 sec duration)		1		1	mA
Forward current I_f at 21°C Average value (CW operation)		5		5	mA
Forward current I_f at 21°C Peak value (1 sec duration)		50		50	mA
Max. total power dissipation		60		60	mW
Soldering (for 1.5 sec.)		260		260	°C

* Extended operating temperature range possible for special design considerations

Electrical Characteristics, $T_a = 25\text{ °C}$, $M = 100$

	SAE230VX			SAE500VX			Units
	Min	Typ	Max	Min	Typ	Max	
Breakdown voltage @ $I_d = 10\text{ µA}$	150	230	300	150	230	300	Volt
Responsivity @ 650 nm	30	38		30	38		A/W
V_{br} temperature coefficient		0.2	0.5		0.2	0.5	V/°C
Dark current		5	30		5	30	nA
Noise current		0.6	1.0		0.6	1.0	pA/ sqrtHz
Capacitance		4	6		4	6	pF
Rise time		450			450		psec

Fig. 1: Spectral Response (M = 100)

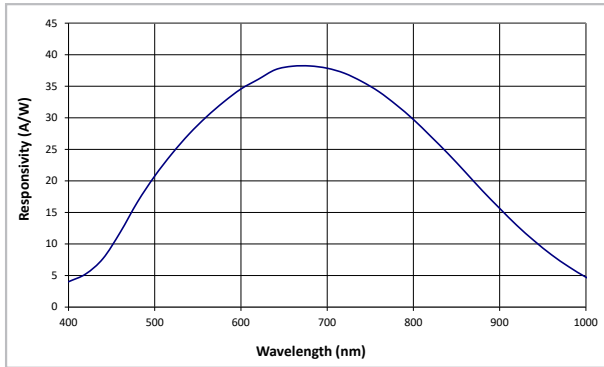

Fig. 2: Quantum Efficiency vs. Wavelength

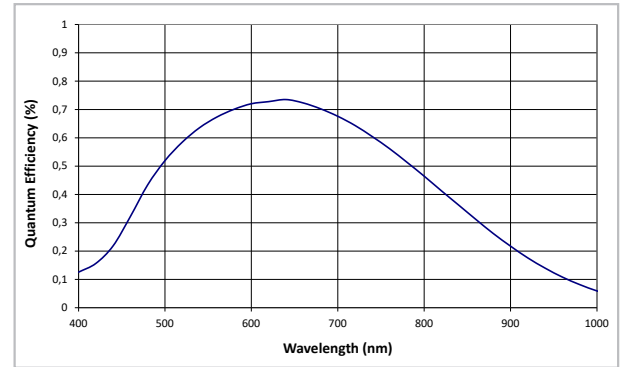

Fig. 3: Typical Dark Current Characteristics

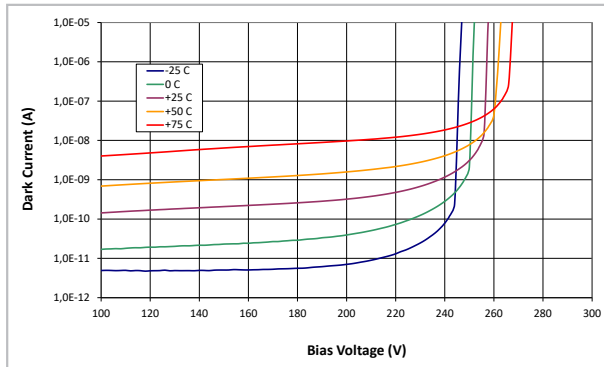

Fig. 4: Gain - Voltage characteristics @ 650 nm

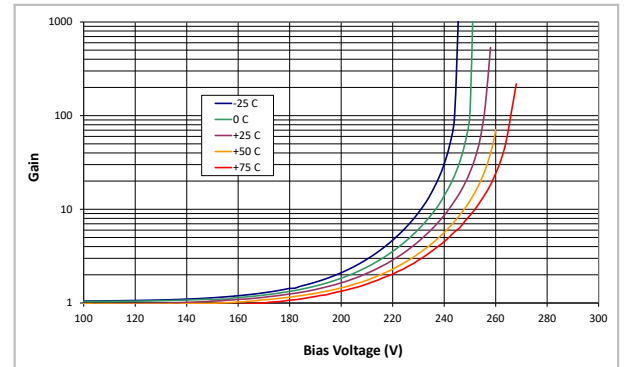

Fig. 5: Capacitance vs. Reverse Voltage

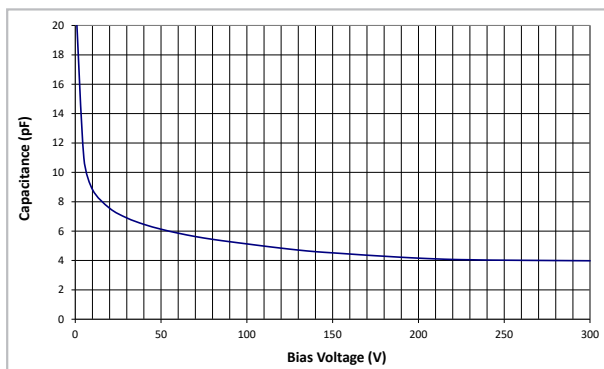

Fig. 5: Typical APD Noise Density as a Function of Gain

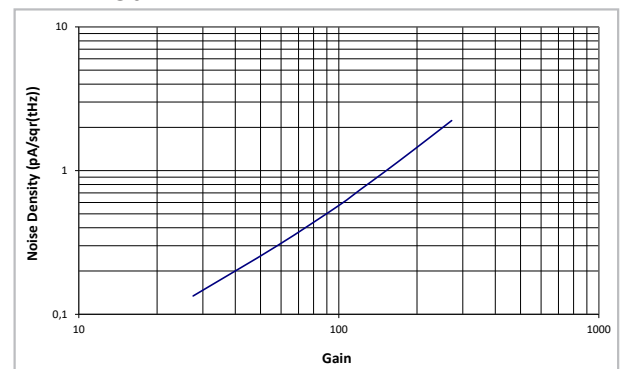
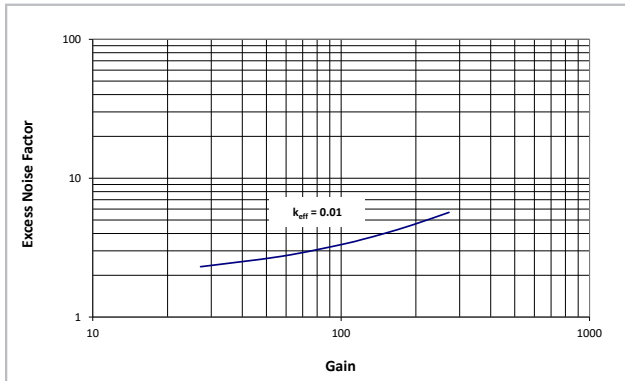
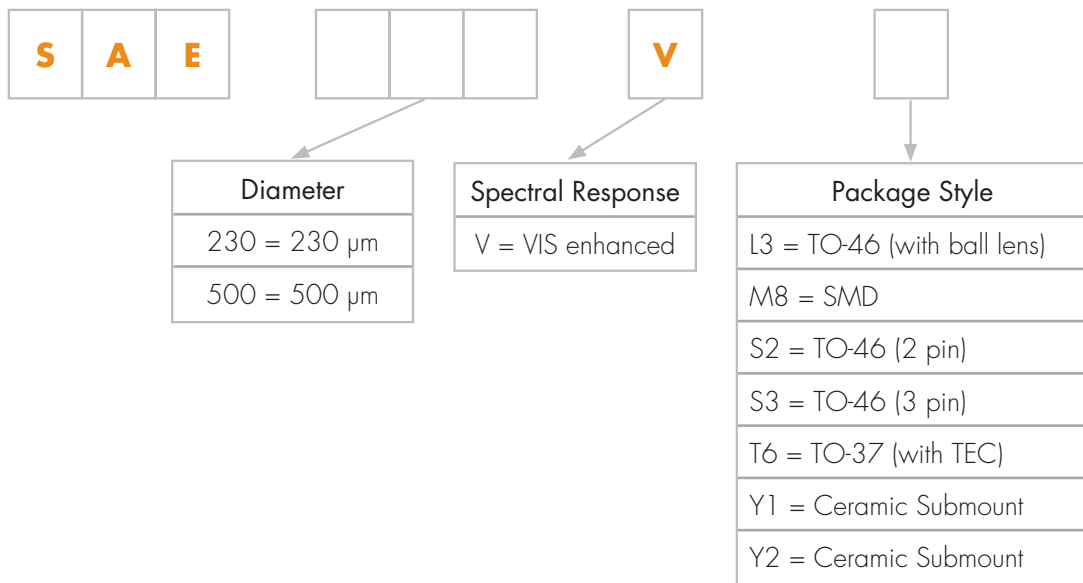

Fig. 7: Excess Noise Factor



Product Number Designations



Package Drawings

Package L3 TO-46 (with ball lens)

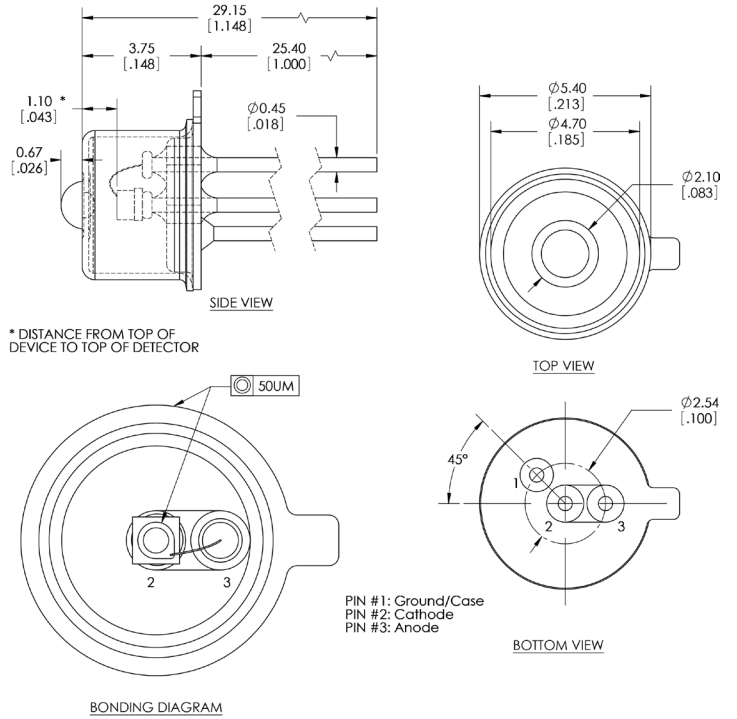
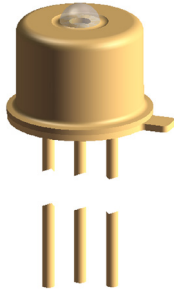

Package M8 SMD

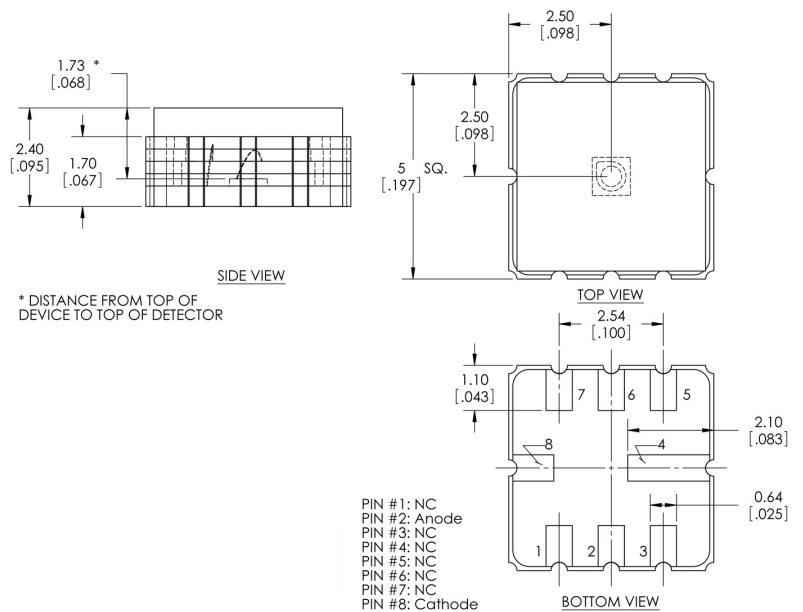
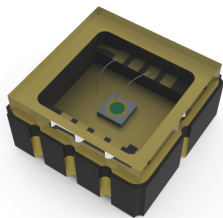

Silicon Avalanche Photodiode
SAE-Series (Red-Enhanced)



Package S2 TO-46 (2 pin)

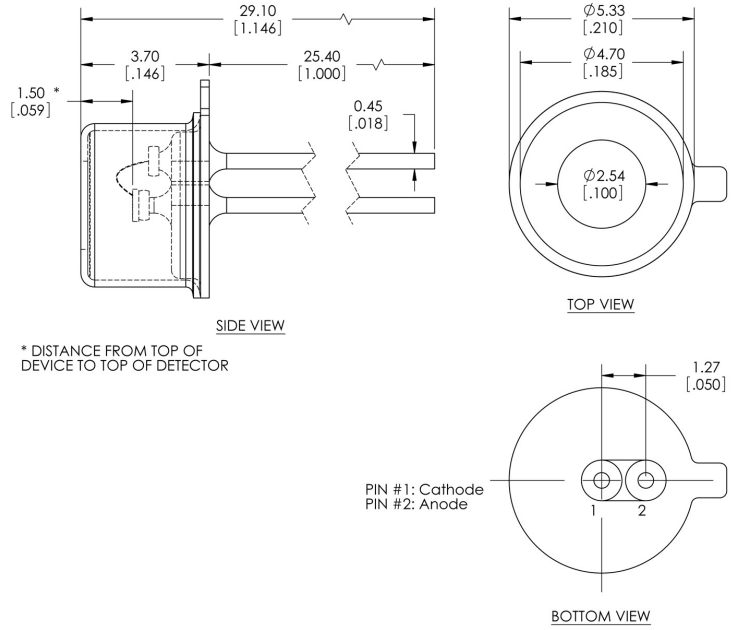
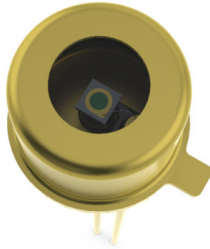

Package S3 TO-46 (3 pin)

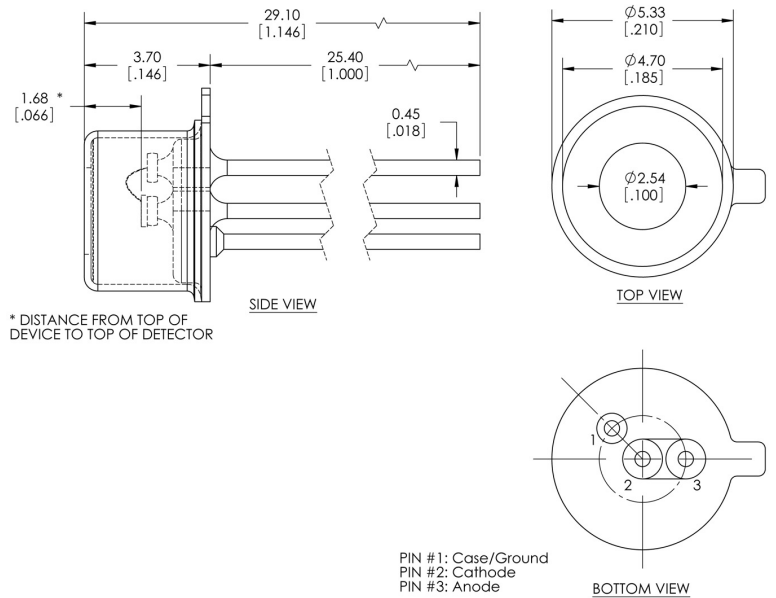
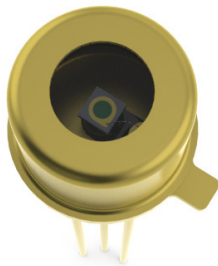

Package T6 TO-37 (with TEC)

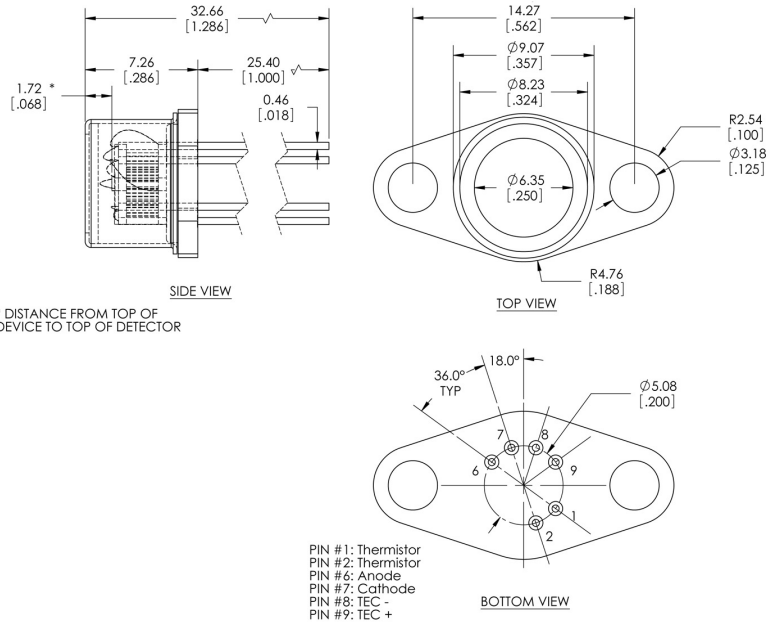
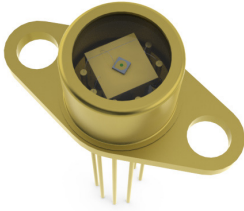

Package Y1 Ceramic Submount

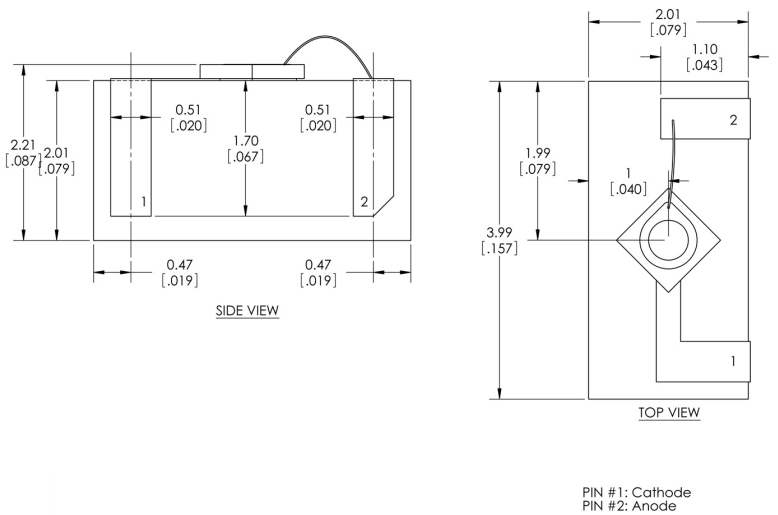
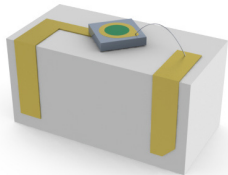

Package Y2 Ceramic Submount

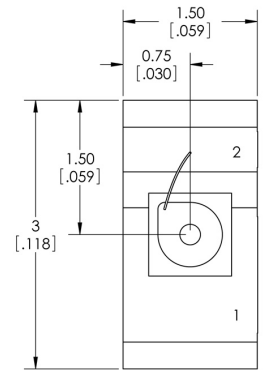
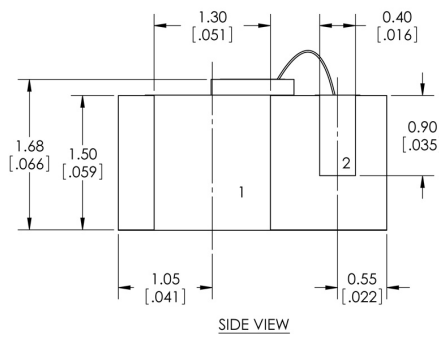
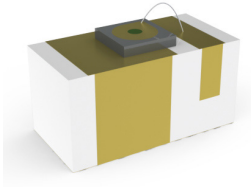

PIN #1: Cathode
PIN #2: Anode

Product Changes

LASER COMPONENTS reserves the right to make changes to the product(s) or information contained herein without notice.

No liability is assumed as a result of their use or application.

Ordering Information

Products can be ordered directly from LASER COMPONENTS or its representatives. For a complete listing of representatives, visit our website at www.lasercomponents.com

Custom designed products are available on request.