

MICRONIX Piezo Motor Patent Primer - Superior Performance Explained

Multi-Phase vs Single Phase Piezo Motor

Piezo Motor Overview

Nano-positioning has become increasingly important in the motion control world due to ever shrinking dimensions in numerous applications. In recent years, long travel piezo driven stages have filled the technology void in nano-positioning with nanometer resolution and high position stability. Historically, piezos were mostly used for very short actuation ranges in the μm to sub-mm range, which required hybrid stages for long travel at nano-meter resolutions. Most recently, piezo motors have emerged that allow unlimited linear and rotary travel.

Most of these piezo motors are based on the friction principle, which allows the limited range of the piezo itself (μm range) to be extended to unlimited travel ranges. Generally, a piezo element actuates a friction element that moves a second friction element (such as a stage carriage). Friction-based piezo motors can be roughly separated into resonant and non-resonant types. **Resonant type piezo motors** exhibit high speed but are not usable at very high resolutions below tens of nm. **Non-resonant piezo motors** operate below the resonant frequency of the piezo and are therefore audible in most cases. However, they allow highly stable nm and sub nm resolutions while at the same time creating unlimited travel.

Some non-resonant piezo motors are based on a friction principle called the stick-slip principle, also sometimes referred to as inertial drive. This principle is explained in greater detail below.

Stick-Slip (Inertial) Piezo Motor

The basic principle of stick-slip inertial motion is the controlled use of friction in connection with the moving part's inertia. As shown in the drawing on the following page, an oscillating piezo element is connected to a friction element which moves the sliding friction element forward when the piezo extends due to an applied voltage. When the piezo is fully extended, which usually occurs after an extension of about $1\ \mu\text{m}$, a fast voltage transition is applied that quickly contracts the piezo to its original position.

The result is a fast backwards motion of the oscillating friction element. However, the inertia of the sliding friction element is too large to completely follow that backwards movement. Similar to a ratchet, this process is repeated until the sliding friction element, which is usually attached to the moving part of the stage, reaches its desired position.

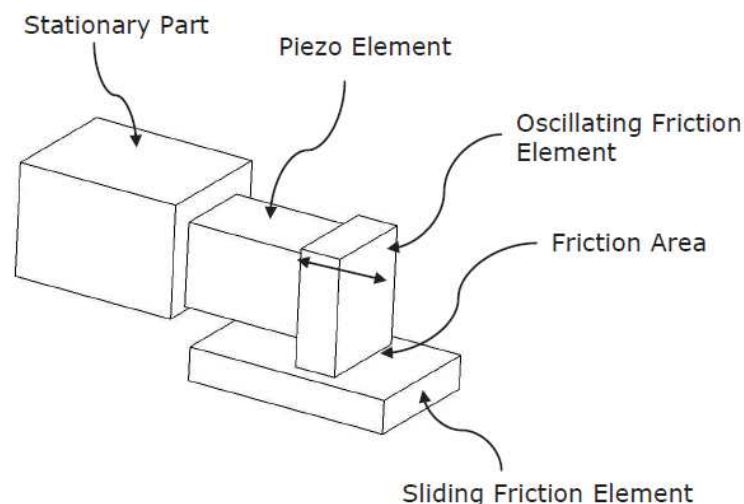

The **main problem with conventional stick-slip** piezo motors is that during the slip phase, the sliding friction element (moving part of the stage) follows the backwards movement to varying degrees. As a result, poor velocity regulation, induced vibration into the system and lost motion (slower velocity and lower efficiency) occur. The following chart shows actual measured results of a commercially available product (motion in μm on the vertical axis and time on the horizontal axis). As can be seen, there is very large backwards motion during every slip phase. The backwards motion amounts to about 50% of the forward motion per cycle.

Traditional Stick-Slip Piezo Motor Performance

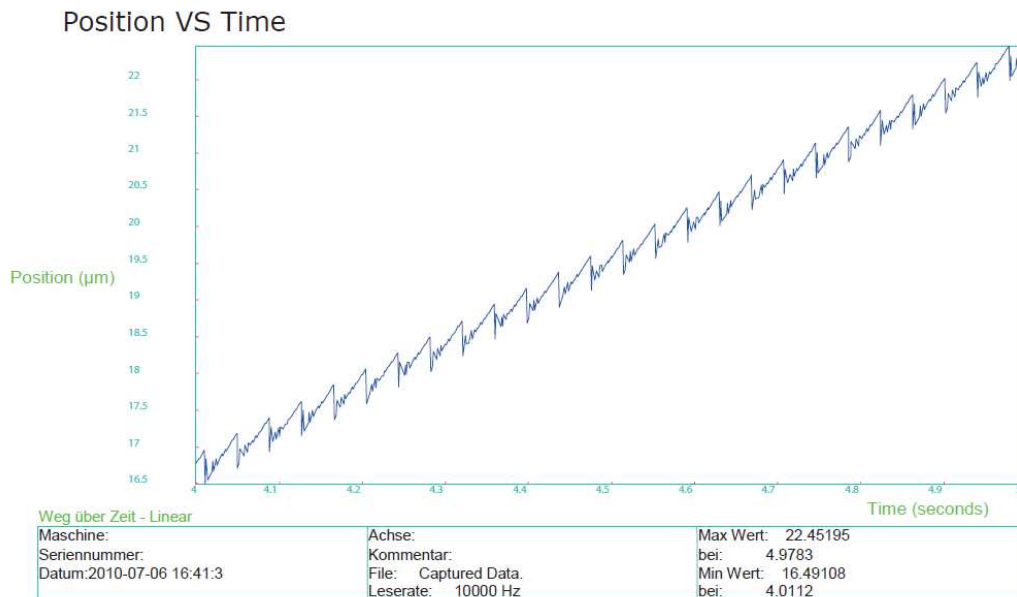

MICRONIX Multi-Phase Piezo Motor Performance (Patented)

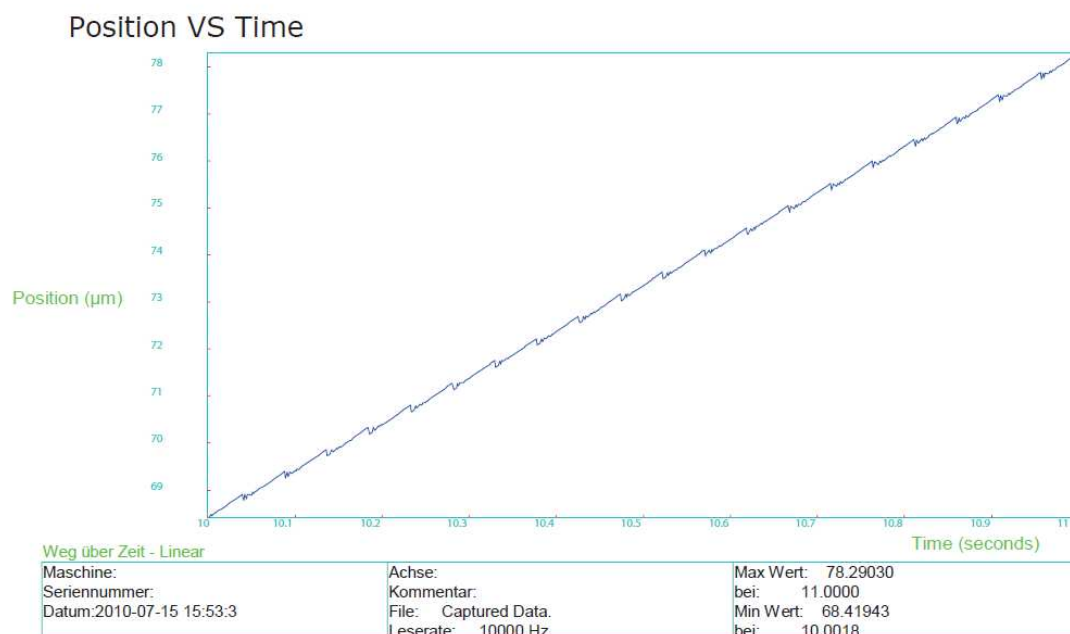

The preceding chart shows the significant improvement achieved by using the MICRONIX Multi-Phase Stick-Slip piezo motor. This motor decreases or completely eliminates the backwards motion during the slip phase because it does not solely rely on the inertia of the moving part. Instead, the MICRONIX piezo motor utilizes at least two piezos and two friction elements that move in unison, but slip at different times. Using this method, the sliding friction elements slip at different times, so at least one element stays in the stick phase while the other one slips. As a result, the retract force and motion induced by the slip force onto the sliding element are reduced or completely eliminated.

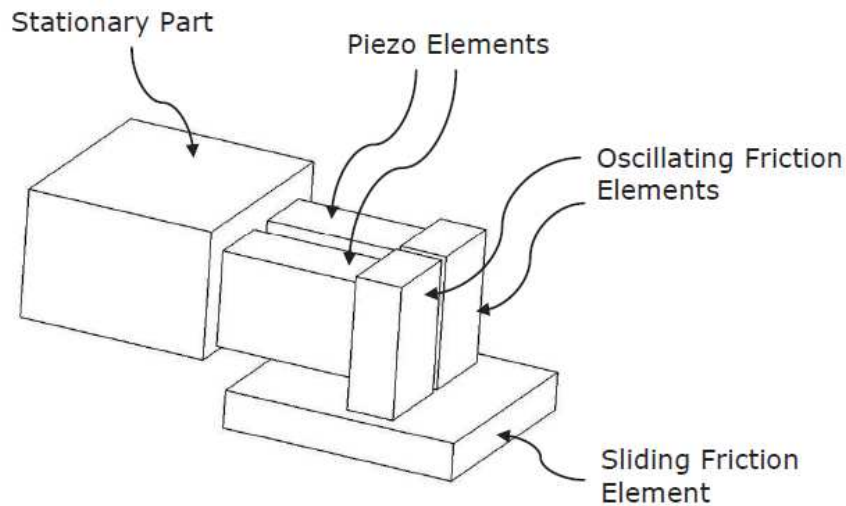

Using the multi-phase principle results in significant performance improvements over single-phase motors, including:

- Higher moving forces
- Better velocity regulation – smoother motion
- Less induced vibration
- More efficient motion

All products listed in this brochure take advantage of our new Multi-Phase Piezo Motor and therefore exhibit the superior performance outlined above.