

Integrating Spheres

AvaSphere 30-REFL



An integrating sphere works as a light collector. The light collected can be used as a diffuse illumination or measurement source. The basic principle is that light enters the sphere through the sample port, goes through multiple reflections on the highly reflective, Lambertian surface of the sphere and is scattered uniformly around the interior of the sphere. Behind a baffled port inside the sphere which is independent of the angular properties of the sample port, a fiber-optic cable collects a homogenized light signal and carries it to the spectrometer. The baffle is very significant as it prevents first reflections from entering the detection fiber.

The AvaSphere series integrating spheres are available with active diameters of 30, 50 and 80 mm and an SMA port at 90 degrees for collecting the irradiance and reflection signals. The reflection spheres feature an additional SMA-connector port at 8 degrees from normal (from sample port) for direct illumination. This port couples external light into the sphere through a fiber-optic cable connected to a COL-UV/VIS collimating lens. The sample port diameters are 6 mm for the AvaSphere-30, 10 mm for the AvaSphere-50 and 15 mm for the AvaSphere-80.

All sample ports are knife-edge, ensuring a near 180 degree field of view of the sample port. The irradiance version of the integrat-

ing sphere can be used for measurements of light sources, such as lasers, LEDs and incandescent sources. For irradiance measurements of 5 mm cylindrical LEDs, a special adapter is available for the AvaSphere-50/80-IRRAD. This adapter ensures correct and reproducible positioning of the LEDs inside the sphere.

The AvaSphere reflection version is used for the measurement of total integrated reflectance of a surface, as well as for color measurements and fluorescence spectroscopy on solids/powders. The principle of measurement is based on direct illumination and indirect reflection.

The AvaSphere-50-LS-HAL with internal light source can be used as a uniform source and is available with an intensity calibration file.

The inside of the integrating spheres is made of a highly reflective diffuse PTFE material. This provides over 96% reflectance over a wide wavelength range of 250-2500 nm. For the AvaSphere-50-REFL a special black gloss-trap is available to exclude specular reflection in the measurement. Please order this option when ordering the sphere. In case specular reflection needs to be included, a white reflective part, which is standard on all AvaSphere-50-REFL, can be mounted in the position of the gloss-trap.

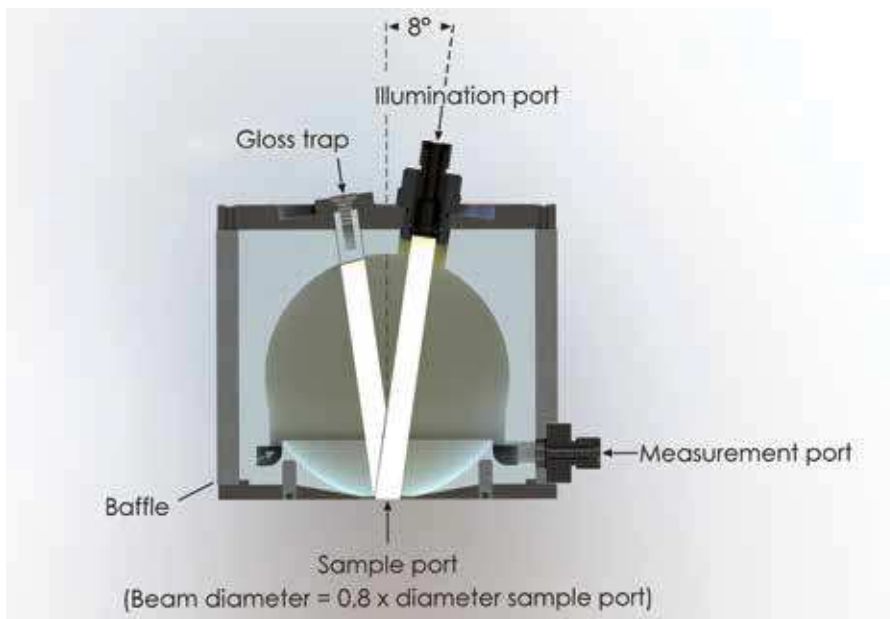

Reflection Integrating Sphere Drawing for AvaSphere-50-REFL

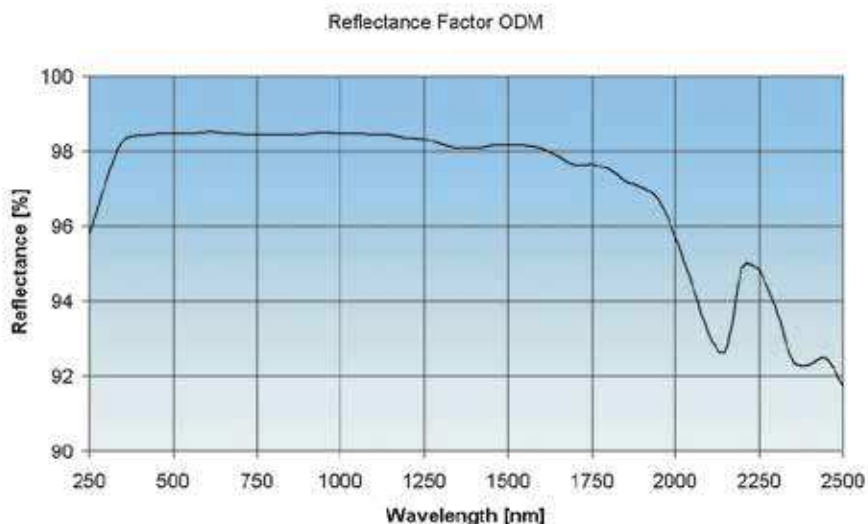

Reflection Curve AvaSphere

Technical Data

	AvaSphere-30	AvaSphere-50	AvaSphere-80
Internal diameter (mm)	30	50	80
Sample port diameter (mm)	6	10	15
External Dimensions	59.5 mm diameter 40 mm height	69.5 mm diameter 60 mm height	109 mm diameter 95 mm height

Ordering Information

AvaSphere-30-IRRAD	• Integrating Sphere 30 mm for light measurements (250-2500 nm), Sample-port 6 mm
AvaSphere-50-IRRAD	• Integrating Sphere 50 mm, Sample-port 10 mm
AvaSphere-80-IRRAD	• Integrating Sphere 80 mm, Sample-port 15 mm
AvaSphere-30-REFL	• Integrating Sphere 30 mm for reflection (250-2500 nm), Sample-port 6 mm, 2 SMA port
AvaSphere-50-REFL	• Integrating Sphere 50 mm for reflection, Sample-port 10 mm
AvaSphere-80-REFL	• Integrating Sphere 80 mm for reflection, Sample-port 15 mm
AvaSphere-50-LS-HAL-12V	• Integrating Sphere 50 mm for reflection, built-in halogen light source, sample-port 10 mm
AvaSphere-LED-ADR	• Cylindrical Adapter to hold 3, 5, 8 mm LED's inside the AvaSphere-50-IRRAD
AvaSphere-LED-ADR-80	• As AvaSphere-LED-ADR, but for AvaSphere-80-IRRAD
AvaSphere-GT50	• Optional Gloss-trap for AvaSphere-50-REFL, coated with black absorbing material. Only in combination with AvaSphere-50-REFL.
AvaSphere-GT50-W	• Gloss-trap coated with white material to include specular reflection. Standard included in AvaSphere-50-REFL.
AvaSphere-50-HOLD	• WS-2 (-GEM) Tile holder for AvaSphere-50-REFL/LS-HAL-12V
AvaSphere-COL-PLUG-W	• Optional replacement for collimating lens on top of AvaSphere-50-REFL to realise IRRAD functionality.

Three years
limited warranty on all
Avantes spectrometers,
light sources and accessories

OPTOPRIM
 Monza (+39) 039.834.997
 Roma (+39) 06.8765.7838
www.optoprim.it info@optoprim.it